

WIN A RASPBERRY PI 3! WE'VE GOT 10 TO GIVE AWAY

# The MagPi

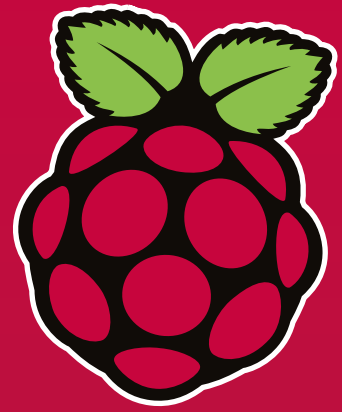

The official Raspberry Pi magazine

Issue 43 March 2016

[raspberrypi.org/magpi](http://raspberrypi.org/magpi)

# RASPBERRY PI

Wireless LAN • Bluetooth • 64-bit • 1.2GHz

## BUILD AN INFINITY MIRROR

2001: A Space Odyssey  
eat your heart out

## HACK MINECRAFT

Write your own Minecraft  
Bedrock Challenge

## PLAY CLEF HERO

Make a music game  
with the Piano HAT

## DIVE WITH WHALES

The award-winning Pi  
project explained

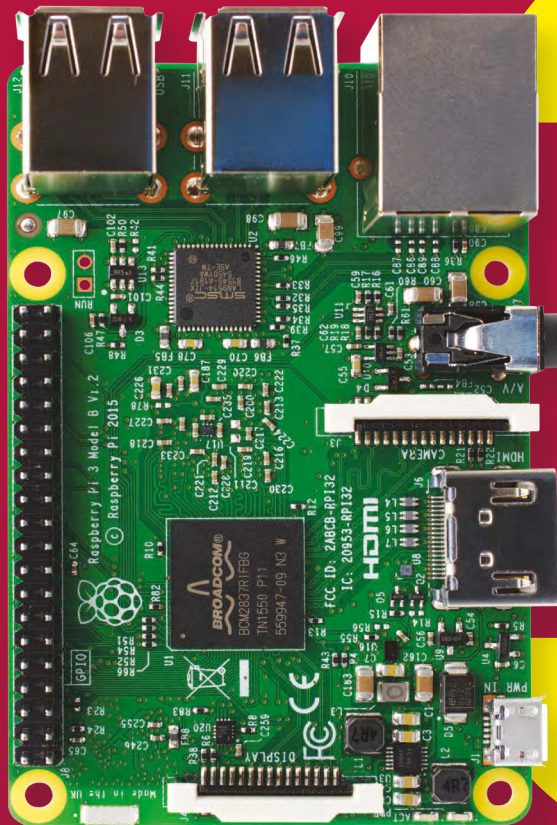

### Also inside:

- > ASTRO PI ISS MISSION UPDATE
- > THE ULTIMATE PI ZERO CLUSTER
- > DO SCIENCE WITH THE SENSE HAT
- > MAKE A PI-POWERED WAKE-LIGHT



## FREE TO SHARE

How & why you should  
give your next project  
an open source licence

Issue 43 • Mar 2016 • £5.99



9 772051 998001

03

THE ONLY MAGAZINE WRITTEN BY THE COMMUNITY, FOR THE COMMUNITY

# VNC SDK now available for

# RASPBERRY PI!

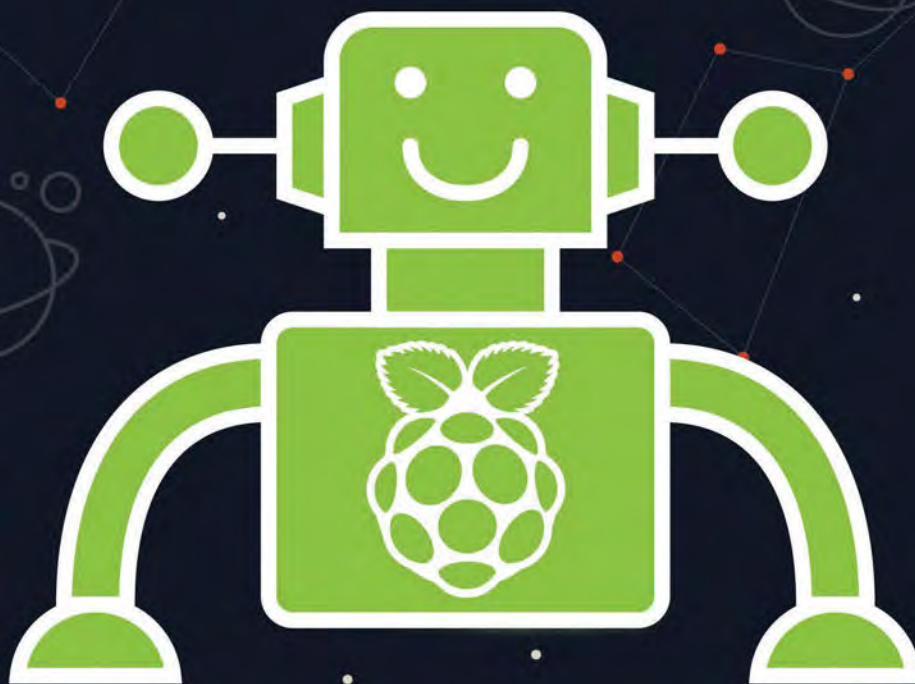

With VNC SDK you can connect VNC Viewers with VNC Servers easily over the Internet. Using VNC Cloud, no complicated network configuration at either end is required!

What will you create with VNC SDK?  
Check it out here: <https://developer.realvnc.com/>

REAL  
VNC

VNC DEVELOPER

Getting connected: [www.realvnc.com/products/vnc/raspberrypi/](http://www.realvnc.com/products/vnc/raspberrypi/)  
For more information contact [vncdeveloper@realvnc.com](mailto:vncdeveloper@realvnc.com)

# Expand your Pi

## Stackable expansion boards for the Raspberry Pi

### Serial Pi Plus

RS232 serial communication board. Control your Raspberry Pi over RS232 or connect to external serial accessories.

### Breakout Pi Plus

The Breakout Pi Plus is a useful and versatile prototyping expansion board for the Raspberry Pi

### ADC Differential Pi

8 channel 18 bit analogue to digital converter. I<sup>2</sup>C address selection allows you to add up to 32 analogue inputs to your Raspberry Pi.

### IO Pi Plus

32 digital 5V inputs or outputs. I<sup>2</sup>C address selection allows you to stack up to 4 IO Pi Plus boards on your Raspberry Pi giving you 128 digital inputs or outputs.

### RTC Pi Plus

Real-time clock with battery backup and 5V I<sup>2</sup>C level converter for adding external 5V I<sup>2</sup>C devices to your Raspberry Pi.

### 1 Wire Pi Plus

1-Wire<sup>®</sup> to I<sup>2</sup>C host interface with ESD protection diode and I<sup>2</sup>C address selection.

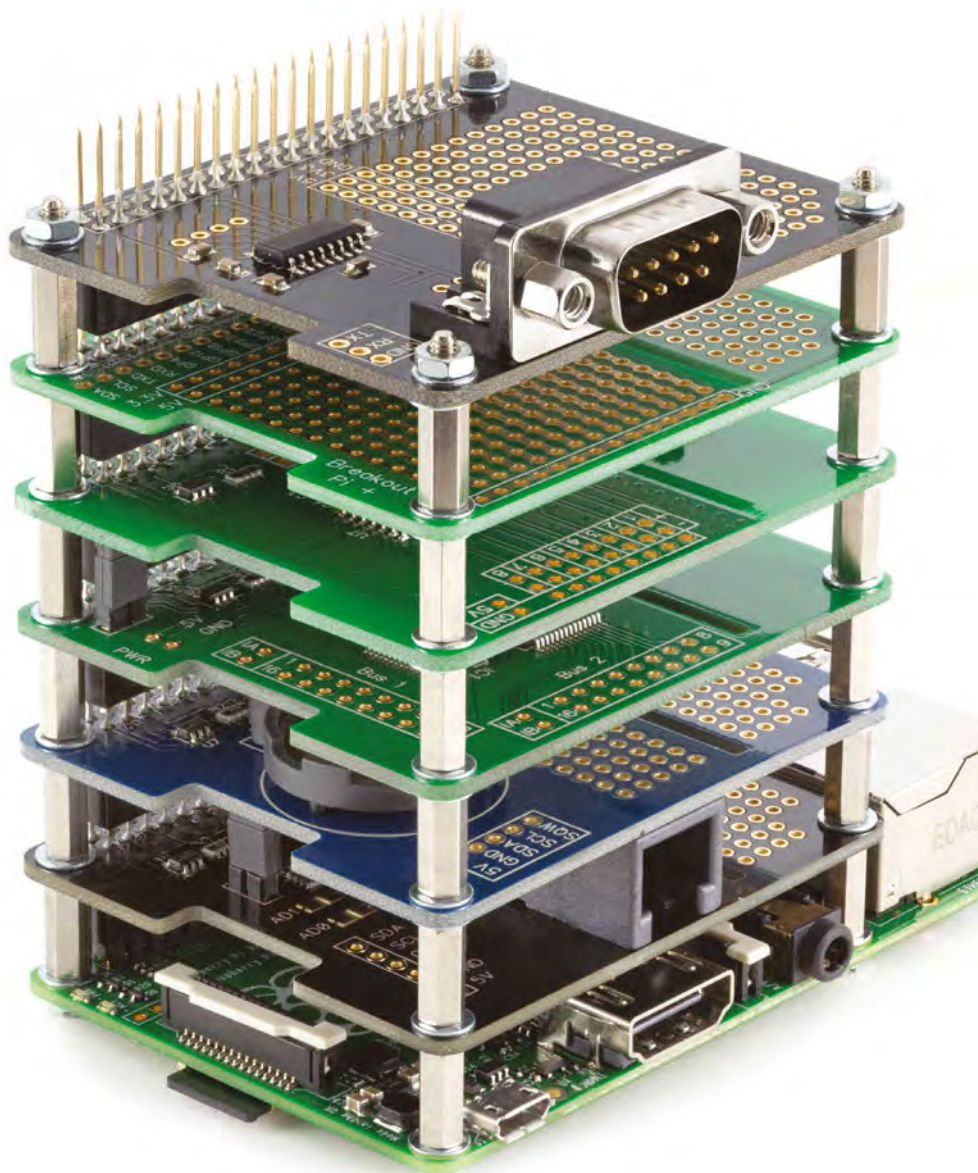

We also stock a wide range of expansion boards for the original Raspberry Pi models A and B

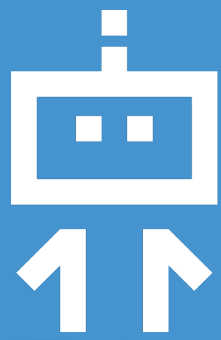

# DEXTER

INDUSTRIES

SAVE  
**15%**  
"MagPi15"  
discount code



## BrickPi

Build a LEGO robot with your Raspberry Pi!

## GoPiGo

Everything you need to build a Raspberry Pi robot!

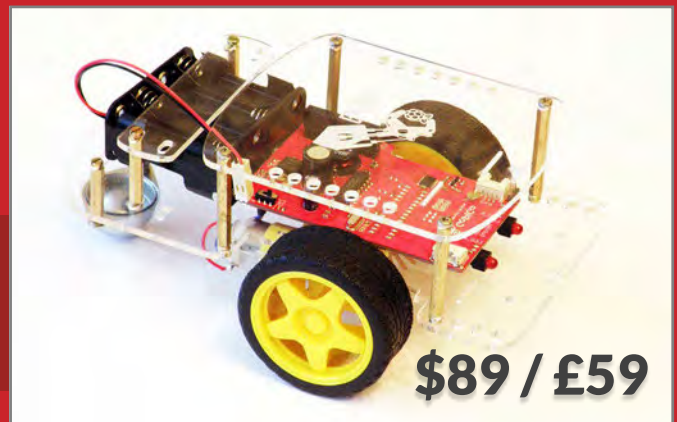

## GrovePi

Connect hundreds of sensors to your Raspberry Pi!

# WELCOME TO THE OFFICIAL PI MAGAZINE!

**T**welve months have passed since *The MagPi* was relaunched as the official Raspberry Pi magazine. Our first issue was a bit of a double-whammy. It came at the time Raspberry Pi was celebrating its third birthday, as well as coinciding with the launch of the Raspberry Pi 2.

Here we are exactly one year on and we're celebrating another birthday and another incredible launch with the Raspberry Pi 3. Featuring built-in wireless LAN, Bluetooth, and a new processor clocked at 1.2GHz capable of 64-bit instructions, the Pi 3 is as a real game-changer for hackers and makers. You can skip ahead just a couple of pages to get the full low-down, including a detailed hardware breakdown, interviews with Raspberry Pi's Eben Upton and James Adams, a full suite of benchmark tests, wireless how-to, and much more besides.

Since we like to go the extra mile for our valued readers, we've also teamed up with **ThePiHut.com** on a fantastic offer for our print subscribers. On 29 February we sent all our print subscribers an email containing a unique code they could use at **ThePiHut.com** to be among the very first people in the world to receive Raspberry Pi's latest credit card-sized PC. You can find all the details of the offer on pages 18-19 (and it's not too late to take part if you're not yet subscribed).

**Russell Barnes**  
Managing Editor



## THIS MONTH:

### 6 THE RASPBERRY PI 3 IS HERE!

We've got everything you need to know and more

### 22 GET SWITCHED ON TO ASTRO PI

Both Ed and Izzy are doing their thing on the ISS!

### 56 TO INFINITY (AND BEYOND)

Cook up a Pi-powered infinity mirror in Mike's Pi Bakery

### 70 MAKE IT FREE TO SHARE

Why (and how) to use open source licences

**FIND US ONLINE** [raspberrypi.org/magpi](http://raspberrypi.org/magpi)

**GET IN TOUCH** [magpi@raspberrypi.org](mailto:magpi@raspberrypi.org)



#### EDITORIAL

Managing Editor: **Russell Barnes**  
[russell@raspberrypi.org](mailto:russell@raspberrypi.org)  
Features Editor: **Rob Zwetsloot**  
Sub Editors: **Laura Clay, Phil King, Lorna Lynch**

#### DISTRIBUTION

**Seymour Distribution Ltd**  
2 East Poultry Ave  
London  
EC1A 9PT | +44 (0)207 429 4000

#### DESIGN

Critical Media: [criticalmedia.co.uk](http://criticalmedia.co.uk)  
Head of Design: **Dougal Matthews**  
Designers: **Lee Allen, Mike Kay**  
Cover photography: **Gareth Halfacree**

#### SUBSCRIPTIONS

**Select Publisher Services Ltd**  
PO Box 6337  
Bournemouth  
BH1 9EH | +44 (0)1202 586 848

#### PUBLISHING

For advertising & licensing:  
[russell@raspberrypi.org](mailto:russell@raspberrypi.org) +44 (0)7904 766523  
Publisher: **Liz Upton**  
CEO: **Eben Upton**

#### CONTRIBUTORS

**Sam Aaron, Wesley Archer, Mike Cook, Gareth Halfacree, Lucy Hattersley, Ozzy, Richard Hayler, Phil King, Sean McManus, Simon Monk, Matt Richardson, James Singleton & Richard Smedley**

This magazine is printed on paper sourced from sustainable forests and the printer operates an environmental management system which has been assessed as conforming to ISO 14001.

The MagPi magazine is published by Raspberry Pi (Trading) Ltd., Mount Pleasant House, Cambridge, CB3 0RN. The publisher, editor and contributors accept no responsibility in respect of any omissions or errors relating to goods, products or services referred to or advertised in the magazine. Except where otherwise noted, content in this magazine is licensed under a Creative Commons Attribution-NonCommercial-ShareAlike 3.0 Unported (CC BY-NC-SA 3.0). ISSN: 2051-9982.



# Contents

Issue 43 March 2016

[raspberrypi.org/magpi](http://raspberrypi.org/magpi)

## TUTORIALS

- > **ADD PUSH NOTIFICATIONS ON MOTIONEYES** **48**  
Use your Pi as a motion-detecting CCTV camera
- > **CONTROL SOUND ON SONIC PI** **50**  
Sonic Pi's creator shows how to shape and sculpt sounds
- > **BUILD A MUSIC GAME** **52**  
Make Clef Hero – a music game for the brilliant Piano HAT
- > **MIKE'S PI BAKERY** **56**  
Build an infinity mirror in part one of this massive guide
- > **MAKE A WAKE-LIGHT** **62**  
Meet the morning more naturally with this Pi-powered light
- > **THE BEDROCK CHALLENGE** **64**  
Build an exciting Minecraft mini-game
- > **SCIENCE WITH THE SENSE HAT** **66**  
Learn about light and colour in this new Sense HAT series

## COVER FEATURE

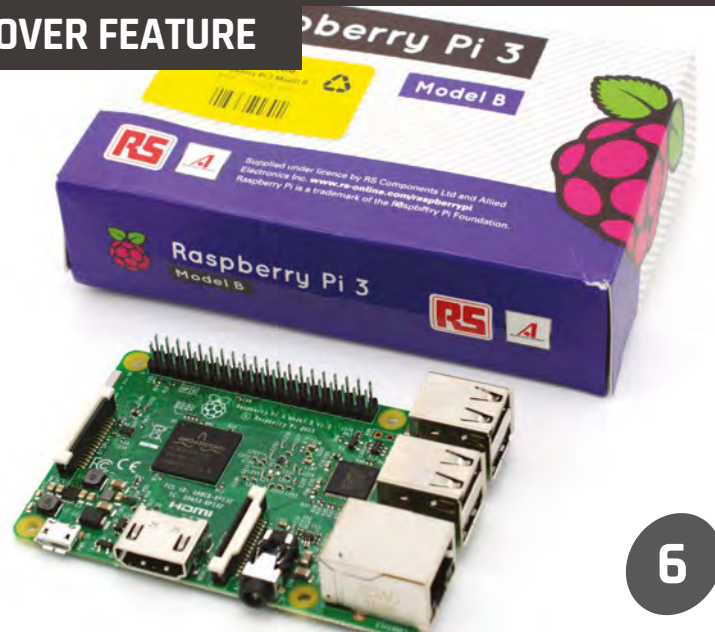

6

## RASPBERRY PI 3

The hottest Pi ever made has arrived. Here's everything you need to know about the new addition to the family, including benchmarks and project ideas

## IN THE NEWS



22

### THE BIG ASTRO PI SWITCH-ON!

Ed and Izzy are finally up and running on the International Space Station. Here's what they're doing

## RIDING WHALES

28

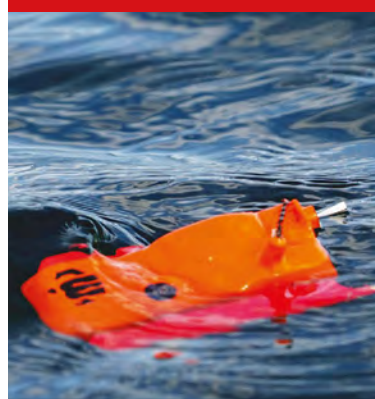

The award-winning Rasp whale project attaches Pi-powered tracking devices to whales



30

### YASMIN BEY

This young enthusiast discovered the Pi and won an award for computing, all in the same year

THE BIG FEATURE

70

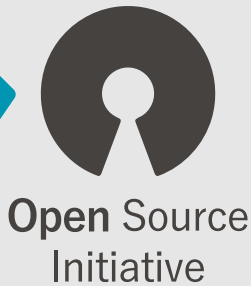

Open Source Initiative

FREE TO SHARE

Here's your essential guide to how (and why) your next Raspberry Pi project should have an open source licence

PI ZERO AVAILABILITY

We catch up with Raspberry Pi's Eben Upton to see what's at the heart of Pi Zero's availability issues

26

10 Raspberry Pi 3s MUST BE WON!

Don't miss your chance to win a brand new Raspberry Pi 3!



95

YOUR PROJECTS

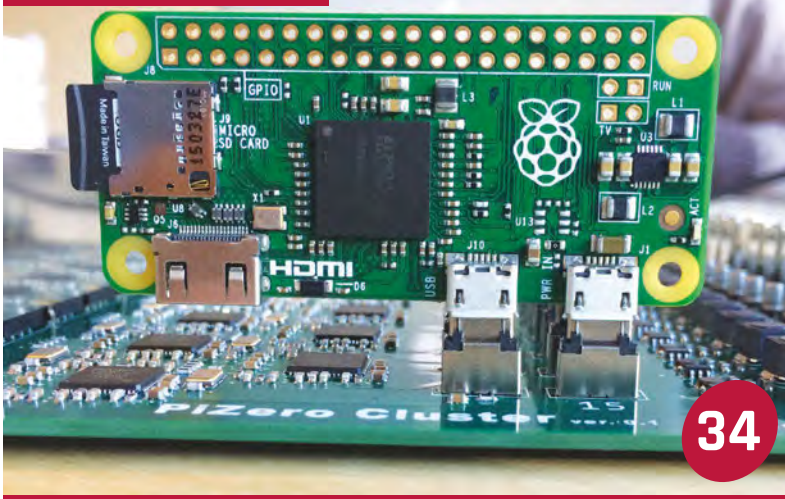

34

THE PI ZERO CLUSTER

Check out this amazing custom board for crunching numbers with Pi Zeros

REGULARS

- > NEWS 22  
The biggest stories from the world of Raspberry Pi
- > TECHNICAL FAQs 68  
Have you got a problem? Yo – we'll solve it
- > BOOK REVIEWS 82  
The latest computer books reviewed and rated
- > THE FINAL WORD 96  
This month Matt talks about affordable connectivity

COMMUNITY

- > THIS MONTH IN PI 84  
What else is happening in the community this month?
- > EVENTS 88  
Find a community gathering near you
- > LETTERS 92  
Two pages for your thoughts on the mag and community

REVIEWS

- > PROSTER VC99 MULTIMETER 76
- > ZEBRA ZERO CASE 78
- > PIMORONI PHAT DAC 79
- > RASPIROBOT V3 BOARD 80
- > KEYES EXPERIMENT KIT 81

STEAMPUNK PI 36

A Raspberry Pi device reimagined for the 19th century. It's a thing of beauty



EYE-PI CAMERA 38

This cool handheld Raspberry Pi IR camera takes stunning and unique shots

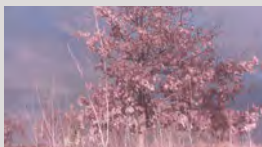

PIDESK 40

Bring some excitement to your office job with this futuristic touch-controlled desk mod



# RASPBERRY PI

64-bit

1.2GHZ

Bluetooth

Wireless LAN





**S**urprise! The Raspberry Pi 3 is here. The latest version of the credit card-sized computer comes a whole year after the launch of its predecessor, the Raspberry Pi 2, and has its own set of upgrades. Here's the highlights: it's faster, it has the exact same form-factor (so your cases still work), and yes, it has wireless on it. Through the course of this feature, we're going to explore all the features of the Raspberry Pi 3 and even benchmark it in six different tests against its siblings. We have an interview with Eben Upton and James Adams about the creation of the Raspberry Pi 3, which also touches on the hurdles involved in adding wireless. Finally, we give you some great tips on how to use your Raspberry Pi 3 and what to use it for. The Raspberry Pi 3 is available from anywhere that will sell you a Raspberry Pi right now, so grab one while reading the rest of the feature!

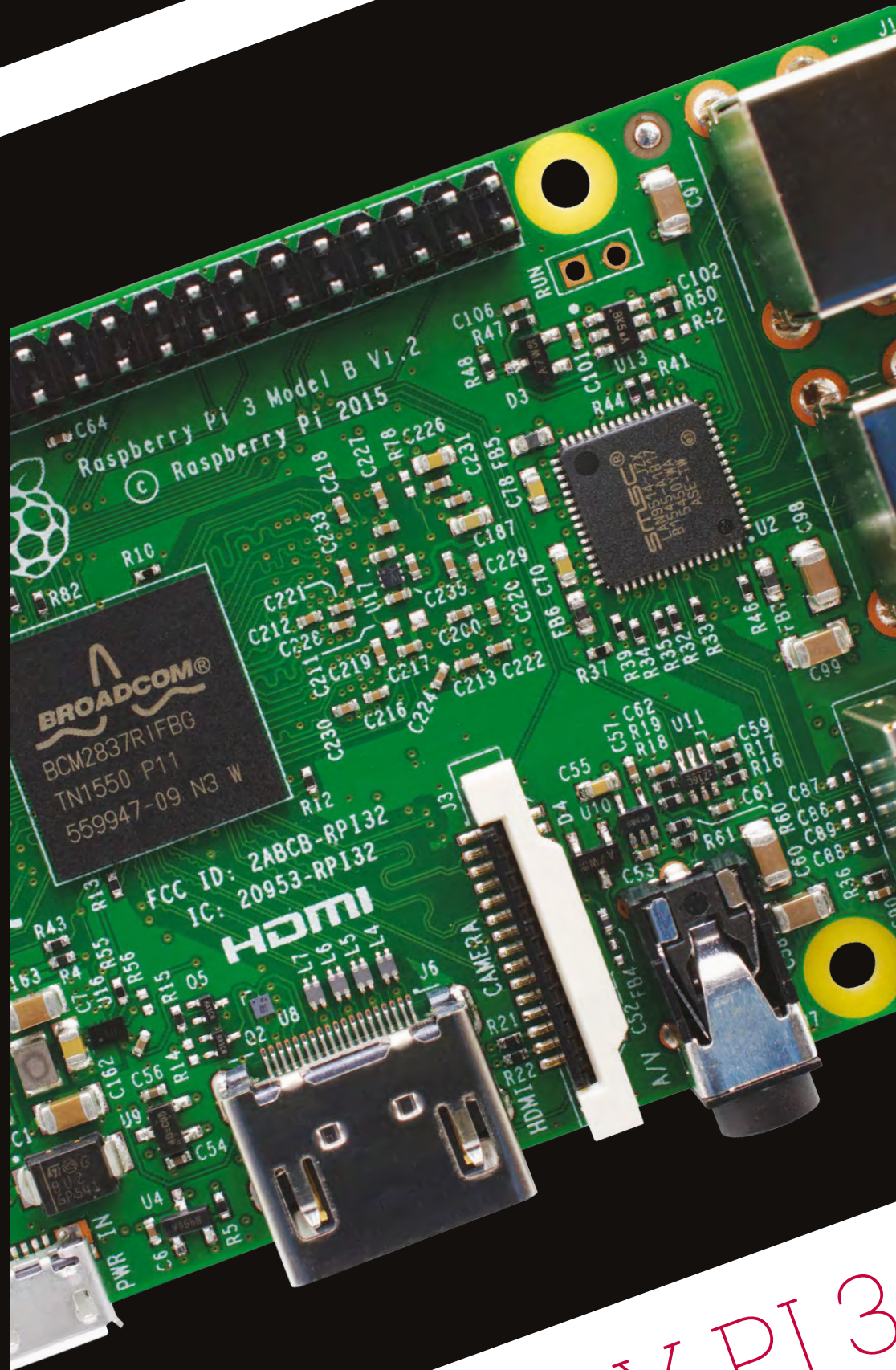

# RASPBERRY PI 3

# INSIDE RASPBERRY PI 3

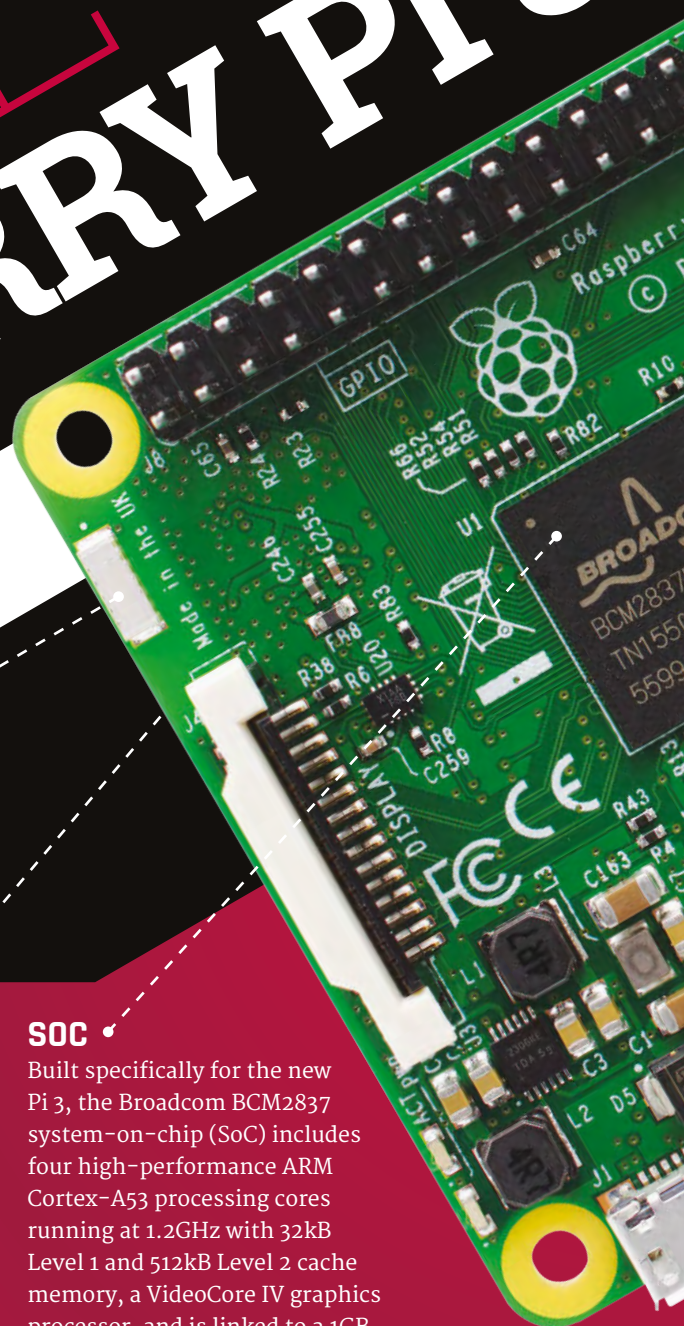

## ANTENNA

There's no need to connect an external antenna to the Raspberry Pi 3. Its radios are connected to this chip antenna soldered directly to the board, in order to keep the size of the device to a minimum. Despite its diminutive stature, this antenna should be more than capable of picking up wireless LAN and Bluetooth signals – even through walls.



## WIRELESS RADIO

So small, its markings can only be properly seen through a microscope or magnifying glass, the Broadcom BCM43438 chip provides wireless LAN, Bluetooth, and Bluetooth Classic radio support. Cleverly built directly onto the board to keep costs down, rather than the more common fully qualified module approach, its only unused feature is a disconnected FM radio receiver.



## SOC

Built specifically for the new Pi 3, the Broadcom BCM2837 system-on-chip (SoC) includes four high-performance ARM Cortex-A53 processing cores running at 1.2GHz with 32kB Level 1 and 512kB Level 2 cache memory, a VideoCore IV graphics processor, and is linked to a 1GB LPDDR2 memory module on the rear of the board.



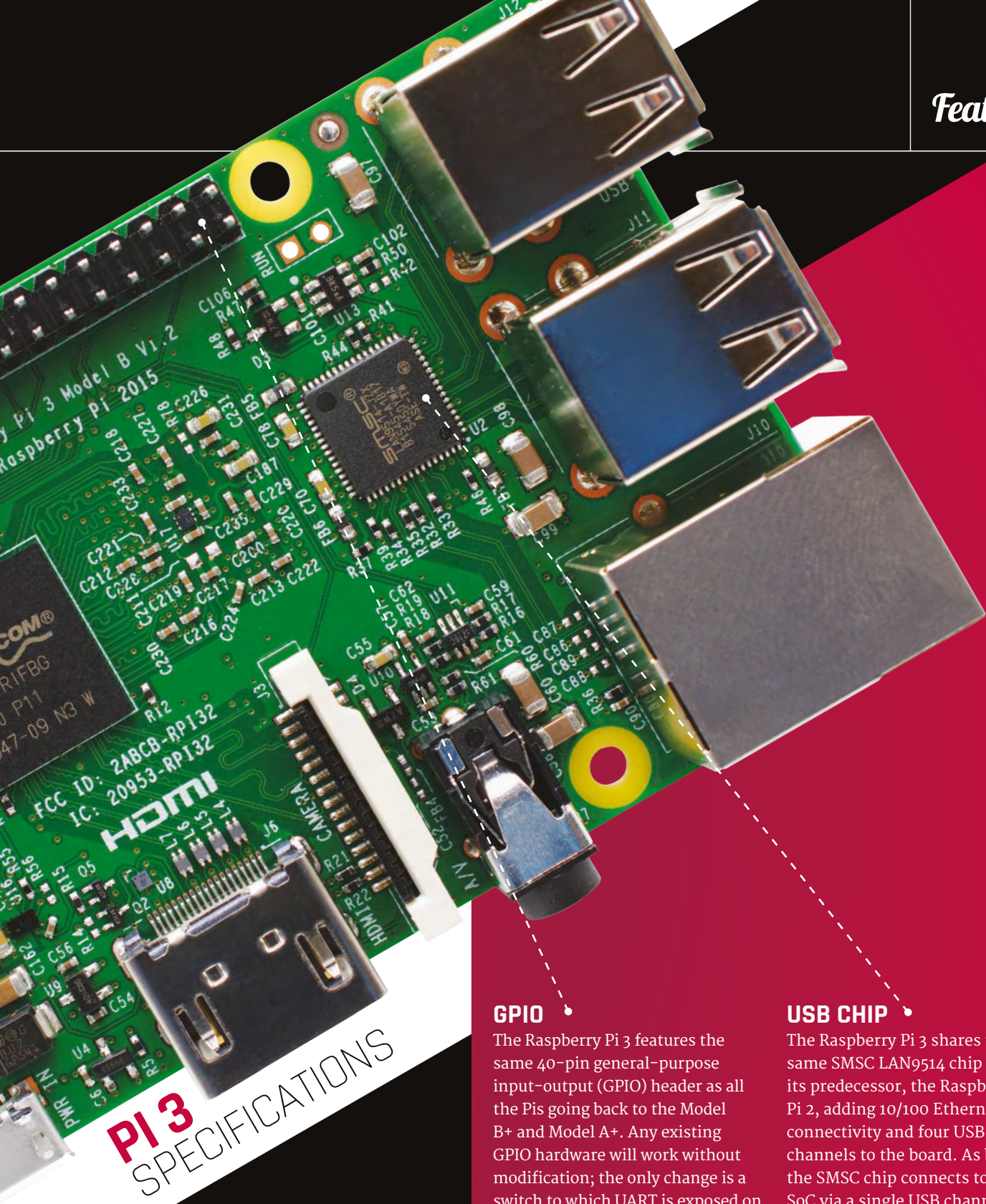

# PI 3 SPECIFICATIONS

## GPIO

The Raspberry Pi 3 features the same 40-pin general-purpose input-output (GPIO) header as all the Pis going back to the Model B+ and Model A+. Any existing GPIO hardware will work without modification; the only change is a switch to which UART is exposed on the GPIO's pins, but that's handled internally by the operating system.



## USB CHIP

The Raspberry Pi 3 shares the same SMSC LAN9514 chip as its predecessor, the Raspberry Pi 2, adding 10/100 Ethernet connectivity and four USB channels to the board. As before, the SMSC chip connects to the SoC via a single USB channel, acting as a USB-to-Ethernet adaptor and USB hub.



- SoC** Broadcom BCM2837
- CPU** 4x ARM Cortex-A53, 1.2GHz
- GPU** Broadcom VideoCore IV
- RAM** 1GB LPDDR2
- Networking** 10/100 Ethernet, 2.4GHz 802.11n wireless
- Bluetooth** Bluetooth 4 Classic, Bluetooth Low Energy
- Storage** microSD
- GPIO** 40-pin header, populated
- Ports** HDMI, 3.5mm analogue audio-video jack, 4x USB 2.0, Ethernet, Camera Serial Interface (CSI), Display Serial Interface (DSI)

# INTRODUCING THE RASPBERRY PI 3

We speak to **Eben Upton** and **James Adams** to find out what makes the latest member of the Raspberry Pi family tick...



It's been four years since the launch of the original Raspberry Pi, and project co-founder Eben Upton has but one word to describe that period: "Packed!" he laughs from his home in a small Cambridgeshire village. "Just sort of non-stop."

"There's just this sense of not really having stopped," he tells us on behalf of the growing Raspberry Pi team. "Of just having worked continuously."

The culmination of the team's ambitions, the Raspberry Pi 3 excites Eben for one main reason: "Connectivity. The other stuff is just quantitative change, it's just faster, more," he explains. "The

wireless and Bluetooth is the big step change on this device. It's something people have asked us for for a long time. It's been this missing element of the platform.

"It wasn't on the original device because it was a million miles beyond us at the kind of scale we were at back then," Eben admits, thinking back to the early days of the Foundation. "We sold 800,000 Raspberry Pis before we hired our first employee. There's no way you could do this sort of stuff with no employees. It's eaten a couple of man-years, probably, getting radio onto the device."

## TESTING

Conformance testing, too, would have been difficult. "You can do all the testing for an unintentional radiator in a couple of days. Pete [Lomas] and I did the original one; Pete, James [Adams], Gordon [Hollingworth], and I did the subsequent products," Eben recalls. "The radio stuff, you give it to a guy and he takes six weeks and just rams through all of these tests. The test campaign for Pi 3 has cost us, basically, £100,000," some ten times that of its radio-free predecessors.

The radio chip isn't the only new feature, of course. The new BCM2837 system-on-chip has been developed specifically for the

project by Broadcom. "It's kind of a mixture of being able to make a business case for it, and then all those people at Broadcom who believed in the mission and were prepared to do the work to get it over the line," Eben explains of how the Foundation was able to convince the multinational chip giant to build custom chips for the project. "That's people from fresh graduate engineers all the way up to people in the C-suite at the top. Tricky, though!"

## USB AND PXE NETWORK BOOT

Even with the chip designed and taped out in March of last year, the Foundation had some final input for Broadcom in order to add two new features: direct USB mass-storage and PXE network boot capabilities. "Gordon rewrote the boot ROM for the chip and then provided an updated boot ROM to Broadcom, saying 'shove this in the chip, it'll work'," Eben laughs. "And it does!"

"The other interesting thing about the chip is for all other ones the implementation work was done entirely in Cambridge; this one was a collaboration with Broadcom's set-top box engineering group in Aztec West [business park] in Bristol."

Eben readily admits that not all the capabilities of the new parts

The tiny BCM43438 chip provides built-in wireless and Bluetooth



**JAMES ADAMS**  
DIRECTOR OF HARDWARE ENGINEERING

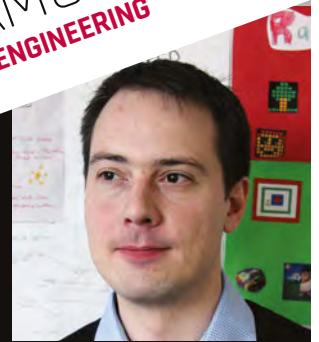

**What were the biggest challenges in adding a radio?**

Firstly, we had to find a solution that would fit into the current Pi form factor with minimal change and that would also be affordable. Secondly was how to connect it to the 2837 processor.

Eben managed to secure a good solution from Broadcom, the BCM43438, and I then set about squeezing it onto the Pi. The layout for the BCM43438 was a real challenge – as, for radio, layout really matters. Connectivity-wise, 2837 actually has two SD card controllers and two UARTs. We decided to look at swapping to the Broadcom SD card controller as the main [one], and using the standard SD controller to talk to the wireless. For Bluetooth, we use the existing UART and swap the UART on the GPIO pins to the second UART.

**What is your circuit design workflow?**

You need to have a completed schematic and then iterate on the layout: place parts and shuffle them around until you can see roughly how the connections will work out before committing to routing the tracks out. It really is part art and part science, and takes a bit of practice before you get a good feel for how to do it well. I also like to make sure all my designs look good, too, but that bit's not strictly necessary!

**Is there anyone you'd like to thank?**

Roger Thornton for managing most of the test-script writing and conformance paperwork as well as plenty of work on the RF side, closely followed by Phil Elwell for sterling work on the Bluetooth and wireless stack, and Kalevi Ratschunas and the team at Broadcom for their hard work on the firmware side. I'd also like to thank Alistair May, who gave us some invaluable help and advice when we were initially getting to grips with the RF engineering challenges.

**If you could add one feature to a hypothetical Pi 4, what would it be?**

That's an easy one: I'd like to see USB 3.0 added, as it really is the universal solution for adding peripherals – especially higher bandwidth ones like disk drives, network interfaces – and removes the requirement for things like SATA.

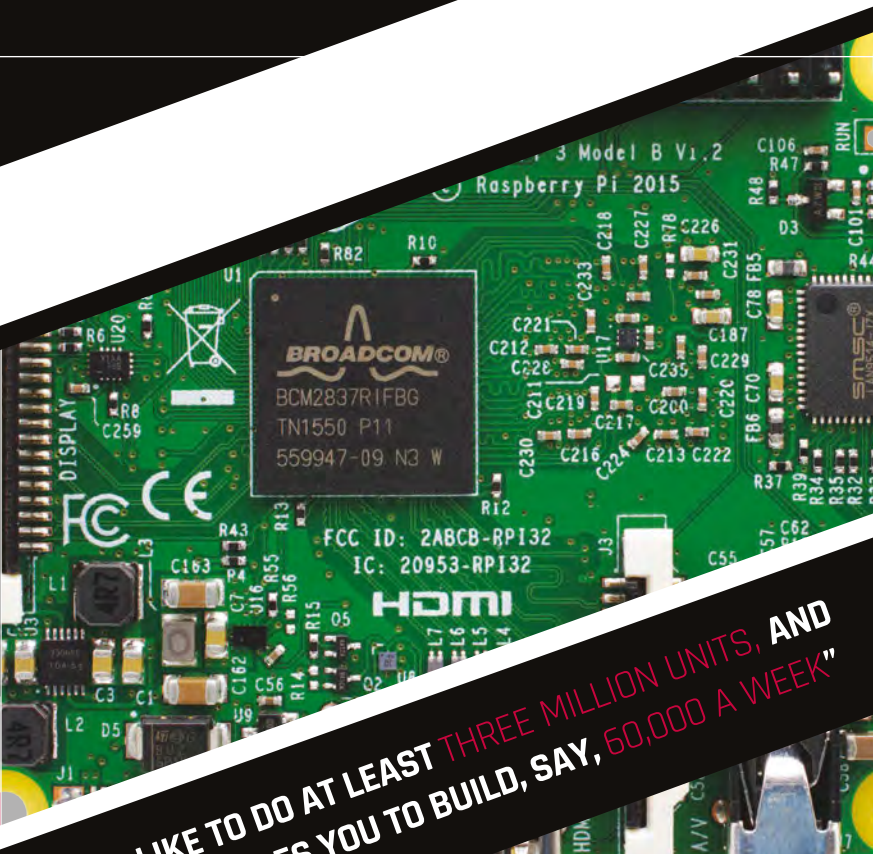

**"I'D LIKE TO DO AT LEAST THREE MILLION UNITS, AND THAT REQUIRES YOU TO BUILD, SAY, 60,000 A WEEK"**

are going to be used at launch, however. "Although it is a 64-bit core, we're using it as just a faster 32-bit core," he reveals about the Pi 3's central processing unit. "I can imagine there'd be some real benefits [to 64-bit code]. The downside is that you do really create a separate world. To access that benefit, you'd have to have two operating systems. I'm hoping that someone will come and demonstrate to me that this is a good idea. But there are some

really compelling advantages to still being basically ARMv6, and because it's [Cortex-]A53 it's a really good 32-bit processor."

Aware of the high demand that a Raspberry Pi launch typically encounters, talk turns to production. "We've already made 30,000 of it," Eben discloses, still some weeks ahead of the release. "I'd like to do at least three million units, and that requires you to build, say, 60,000 a week. We'll probably build around 100,000 a week in the UK, plus whatever Embest builds in China, for a month or two, then you back off to maybe 60,000 a week."

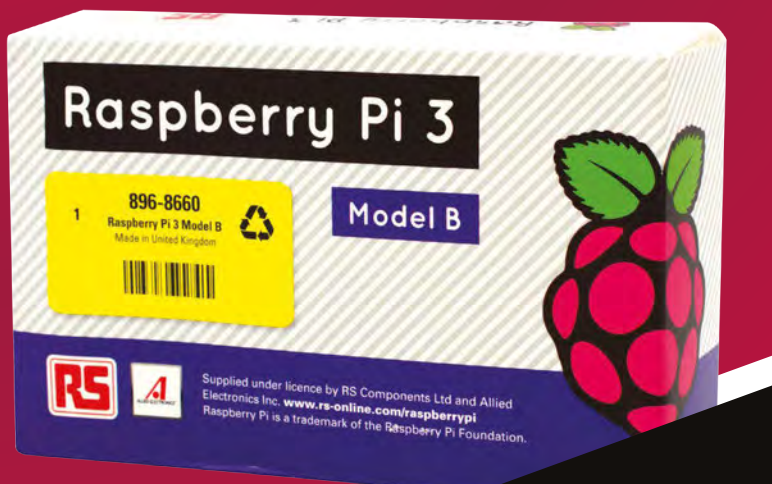

# RASPBERRY PI 3 BENCHMARKS

How does the new Raspberry Pi 3 compare? We pit it against the current Pi models to find out which is fastest of the lot...

**W**hat's the point of the launch of a new piece of technology without some form of performance benchmark? None, we say, and as the Raspberry Pi 3 promises to be that much more powerful than its predecessors, we thought we'd put it through the full range of tests to see how it compares to the Model B+, A+, Zero, and Raspberry Pi 2.

As well as the usual rounds of different tests on how powerful the processor is, we're testing the frame rate in *Quake III*, and even looking at power draw. The last one is important for many makers, and we'd be remiss not to include it.

Like any test of this nature, this all involves perfect conditions and pure number performance, so it won't always translate to real-world performance. It's definitely a good guide, though.

## PYTHON GPIO (kHz)

The higher the better

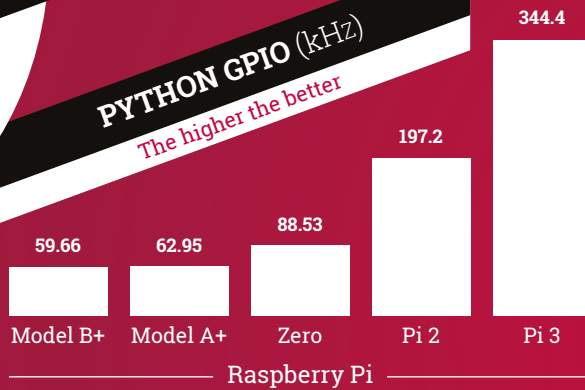

The Raspberry Pi's GPIO pins are most commonly used with Python, but this leads to a CPU bottleneck. In this test, a simple RPi.GPIO program toggles a pin as rapidly as possible while a frequency counter measures how quickly it actually switches.

## WHETSTONE (MWIPS)

The higher the better

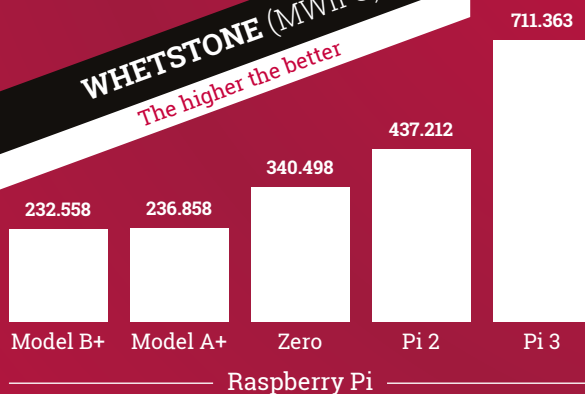

Developed by B.A. Wichman in the 1970s as a means of measuring a computer's speed, the Whetstone benchmark concentrates on floating-point performance. Despite its age, the benchmark offers a good insight into the peak floating-point performance of a processor.

### DHRYSTONE (MIPS)

The higher the better

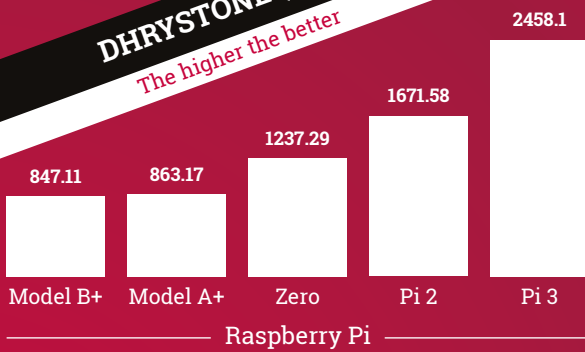

Where Whetstone measures floating-point performance, Dhrystone was developed in the 1980s by Reinhold P Weicker to measure integer – or whole-number – performance. As with its floating-point equivalent, Dhrystone is still a useful synthetic benchmark for comparing different chips.

### SYSBENCH CPU

The lower the better

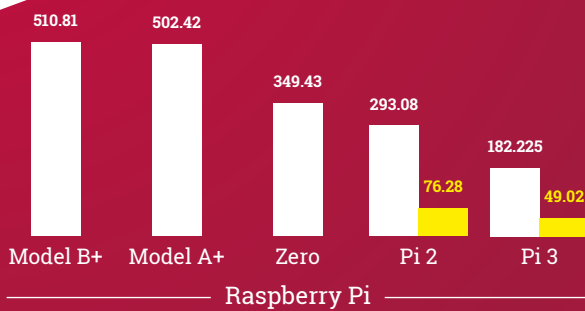

■ SINGLE-THREADED (SECS) ■ MULTI-THREADED (SECS)

Offering support for multi-threaded operation – taking advantage of the four processing cores on the Pi 2 and Pi 3 – SysBench reveals just how far we’ve come since the original Raspberry Pi design. While single-threaded performance has improved greatly, the biggest gains go to multi-threaded programs.

### QUAKE III ARENA TIMEDEMO

The higher the better

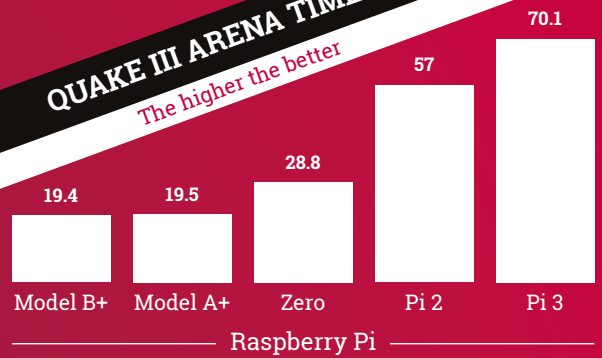

The classic twitch shooter from industry pioneer id Software, *Quake III Arena* is heavily tied to the CPU performance of the Pi. The standard ‘timedemo’ was run at 1280x1024, high geometric, maximum texture detail, 32-bit texture quality, and trilinear filtering to obtain these results.

### POWER DRAW

The lower the better

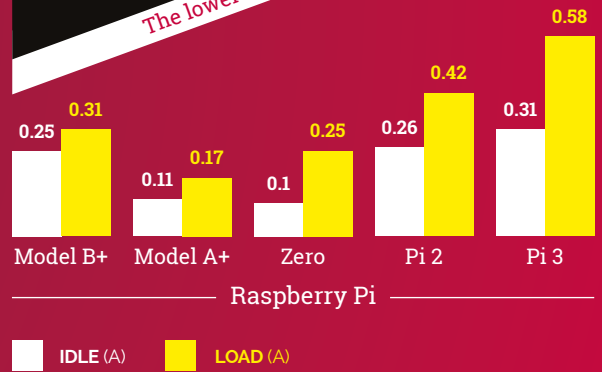

You can’t get extra performance without a few sacrifices. The Pi 3 draws the most power of the test group, but its extra performance means it spends more time at idle. Those looking for maximum battery life should look at the Model A+ or the Pi Zero as an alternative.

# USING THE PI 3'S WIRELESS RADIO

The biggest new feature of the Raspberry Pi 3 is undoubtedly its on-board wireless LAN connectivity, allowing users to connect to a wireless network without tying up a USB port

## You'll Need

- > Raspberry Pi 3
- > 2.4GHz 802.11b/g/n wireless network
- > Your network name (SSID)
- > Your network key (PSK)

**T**he inclusion of a Broadcom BCM43438 radio chip on the Raspberry Pi 3 means it's the first model to offer built-in wireless networking. For anyone who has used a USB wireless dongle with a Pi before, configuration will be straightforward; for everyone else, here's how you hook your Pi 3 up to your wireless network.

The Raspberry Pi 3's on-board wireless radio has drivers pre-installed in the latest version of Raspbian, but if you're upgrading

from an older installation, you'll need to install them manually. Connect the Pi to a wired network, open a terminal, and type the following:

```
sudo apt-get update
sudo apt-get dist-upgrade
```

Reboot to apply the changes.

## CONNECTING FROM THE DESKTOP

The easiest way to connect to a wireless network is through the desktop. The network icon can be found at the top-right of the screen, near the system clock. If you have a wired Ethernet cable connected, disconnect it now. Click the icon to view a list of

wireless networks within range. Find the network matching your network name (known as the SSID), then click on it to begin connecting. If your network doesn't appear, it may be out of range; try moving the Pi and the access point or router closer together and trying again.

If your network is encrypted with WEP or WPA, – you'll be prompted for the network key, also known as the pre-shared key or PSK. If you're not sure what this is, it's usually written on the underside of your access point or router, or on a card attached to the back. Type this in carefully, making sure it matches, and click the OK button.

The network icon will change into a wireless symbol, which fills

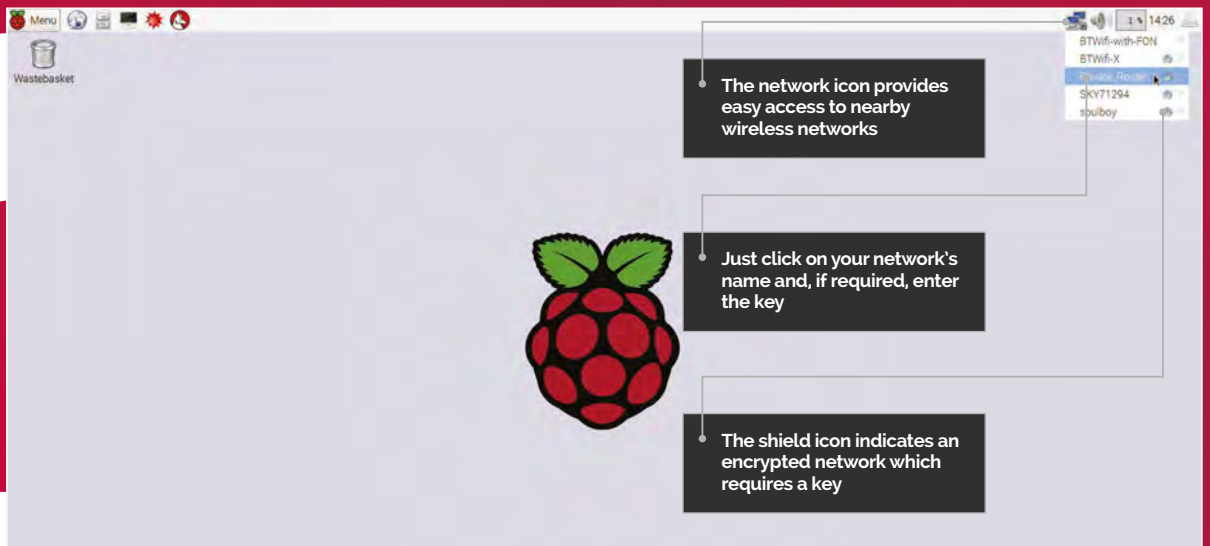



# RASPBERRY PI 3 TIPS AND TRICKS

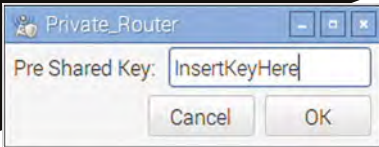

up blue as it tries to connect. If the connection is successful, it will stabilise and display the current signal strength; if not, make sure you chose the right network name and entered the correct key.

## CONNECTING FROM THE COMMAND LINE

If you are using the Lite version of Raspbian, without the desktop, you'll need to configure your wireless network at the command line instead. At the console, type the following command:

```
sudo nano /etc/wpa_
supplicant/wpa_supplicant.
conf
```

Scroll to the bottom of the file, and enter a network definition using the following template:

```
network={
    ssid="NetworkName"
    psk="NetworkKey"
    key_mgmt=WPA-PSK
}
```

...where **NetworkName** is your network's SSID and **NetworkKey** is the encryption key. If connecting to a WEP rather than WPA/WPA2 network, put **key\_mgmt=NONE**. If connecting to an open network, you only need the SSID.

Save the file with **CTRL+O**, then exit with **CTRL+X**. In a few seconds, your Pi should connect to the network. You can test this with the following command:

```
ifconfig wlan0
```

## How to transfer your microSD card

The best way to use your new Raspberry Pi 3 is with a fresh Raspbian or NOOBS installation. To use an existing Raspbian microSD card with the Pi 3, you'll need to make a modification.

In your older Pi, boot Raspbian and open a terminal. Type the following command:

```
sudo apt-get update
sudo apt-get dist-upgrade
```

Shut the Pi down:

```
sudo shutdown -h now
```

Transfer your microSD card to your Pi 3 and your existing operating system will boot. Finally, make sure you're up to date:

```
sudo apt-get update
sudo apt-get upgrade
```

## Enabling OpenGL acceleration

Available exclusively on the Raspberry Pi 2 and 3 thanks to their increased RAM, OpenGL 3D acceleration support is currently in the experimental stage. You can enable the new driver with the following command:

```
sudo apt-get update && sudo apt-get
install xcompmgr libgl1-mesa-dri
```

Be warned, though: with the OpenGL driver installed, you'll no longer be able to swap your microSD card between the Pi 2 or Pi 3 and any other model, as it will fail to boot on any Raspberry Pi with less than 1GB of RAM.

## Use the 2.4GHz band

The BCM43438 has a single-band wireless radio. You need to be running a 2.4GHz-only or dual-band 2.4/5GHz network to successfully connect.

## Programming for the Raspberry Pi 3

If you're writing new software for the Raspberry Pi, or porting existing software

across, there are a few tricks that will help you get the most out of the Raspberry Pi 3...

### > Write multi-threaded applications:

Where you can, make your software multi-threaded. The Pi 2 and Pi 3 both feature quad-core processors, and a fully threaded application will run up to four times faster than one which runs in a single thread. In scenarios where true multi-threading isn't possible, look at spawning multiple copies of your program and splitting the workload between them.

> **Use NEON extensions:** ARM's NEON single-instruction multiple-data (SIMD) extensions are fully supported on the BCM2836 and BCM2837 chips used in the Pi 2 and 3, and using them offers an impressive speed boost: switching from the standard Linpack benchmark on the Pi 3 to a version compiled with NEON support boosts its score from 193MFLOPs to 459MFLOPs. NEON applications, however, won't run on the BCM2835 used on the B+, A+, and Zero.

> **Investigate 64-bit support:** At present, the 64-bit Cortex-A53 cores on the Raspberry Pi 3 are used exclusively in 32-bit mode. If you're looking to port a new operating system to the Pi 3, consider doing so as a native 64-bit version; if you can prove that doing so offers a performance advantage, we may see an official 64-bit Raspbian build released in the future.

## Bluetooth support

At the time of writing, the driver for Bluetooth Classic and Bluetooth Low Energy modes has not yet been finalised. By the time you read this, however, you should be able to install the modules after the aforementioned `apt-get dist-upgrade` using:

```
sudo apt-get install pi-bluetooth
```

For more information on how to use Bluetooth on Pi 3, please read the launch blog post at [raspberrypi.org](http://raspberrypi.org).

# 5

# THINGS TO DO WITH YOUR PI 3

We've compiled five new things you can do with a Raspberry Pi 3...

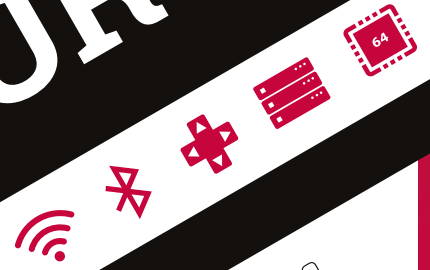

## 1 BUILD A WIRELESS SENSOR NETWORK



**T**he launch of the shiny new Raspberry Pi 3 brings with it an exciting combination of improved performance and new functionality, but all the features in the world aren't much use if you don't have any ideas. Here are our suggestions for five new uses for the Pi 3, made possible by improvements made by the Raspberry Pi Foundation.

The Broadcom BCM43438 radio chip is high-performance yet low-power, making it perfect for building your own sensor networks. Connect everything from temperature sensors to cameras to your Raspberry Pi 3 and have it communicate its findings via wireless LAN for quick and easy Internet of Things (IoT) goodness, or drop the power draw further and build a Bluetooth Low Energy network with multiple Pi 3 systems. For remote installations, try pairing to a cheap second-hand GSM mobile handset via Bluetooth Classic.

## 2 STREAM AUDIO VIA BLUETOOTH



As well as wireless 802.11n and Bluetooth Low Energy, the BCM43438 chip supports Bluetooth Classic mode, including the Advanced Audio Distribution Profile (A2DP). Support for A2DP means it's possible to configure a Pi 3 as a streamer, either receiving audio from a device such as a smartphone or tablet for amplification via HDMI or analogue outputs, or sending its own audio to a remote A2DP destination such as a Bluetooth-enabled soundbar or hi-fi system. You can even build on existing Pi-powered Bluetooth projects without having to buy a USB radio dongle.

### 3 PLAY MORE COMPLEX GAMES



The Raspberry Pi has always had a powerful graphics processor, and now that the central processor can keep up, we're going to see increasingly complex games being built on the system. For those who enjoy the classics, the Pi 3's increased performance means smoother emulation in general, plus support for emulating newer or more demanding systems and titles. For others, there's promise that future Pi games will be able to give mainstream titles a real run for their money in the graphics department.

### 4 BUILD A THIN CLIENT INFRASTRUCTURE



We've seen the Raspberry Pi used to build a pseudo thin-client infrastructure in the past, but the need for local storage in the form of the microSD card has kept it from being a truly thin implementation. The promised support for PXE network boot means that a Pi 3, unlike any other model, can be used as a thin client without the need for any local storage, decreasing deployment cost and increasing reliability – and no more risk of anyone walking off with the SD card!

### 5 RUN 64-BIT CODE



The BCM2837 at the heart of the Pi 3 uses the 64-bit ARMv8 microarchitecture, compared to the 32-bit ARMv7 and ARMv6 of previous models. As well as widening compatibility for running other operating systems, the shift to 64-bit holds the potential to improve performance – but it's going to be up to the community to demonstrate that splitting Raspbian into 32-bit and 64-bit variants offers advantages enough to outweigh the headache of maintaining and supporting two distinct operating system builds.

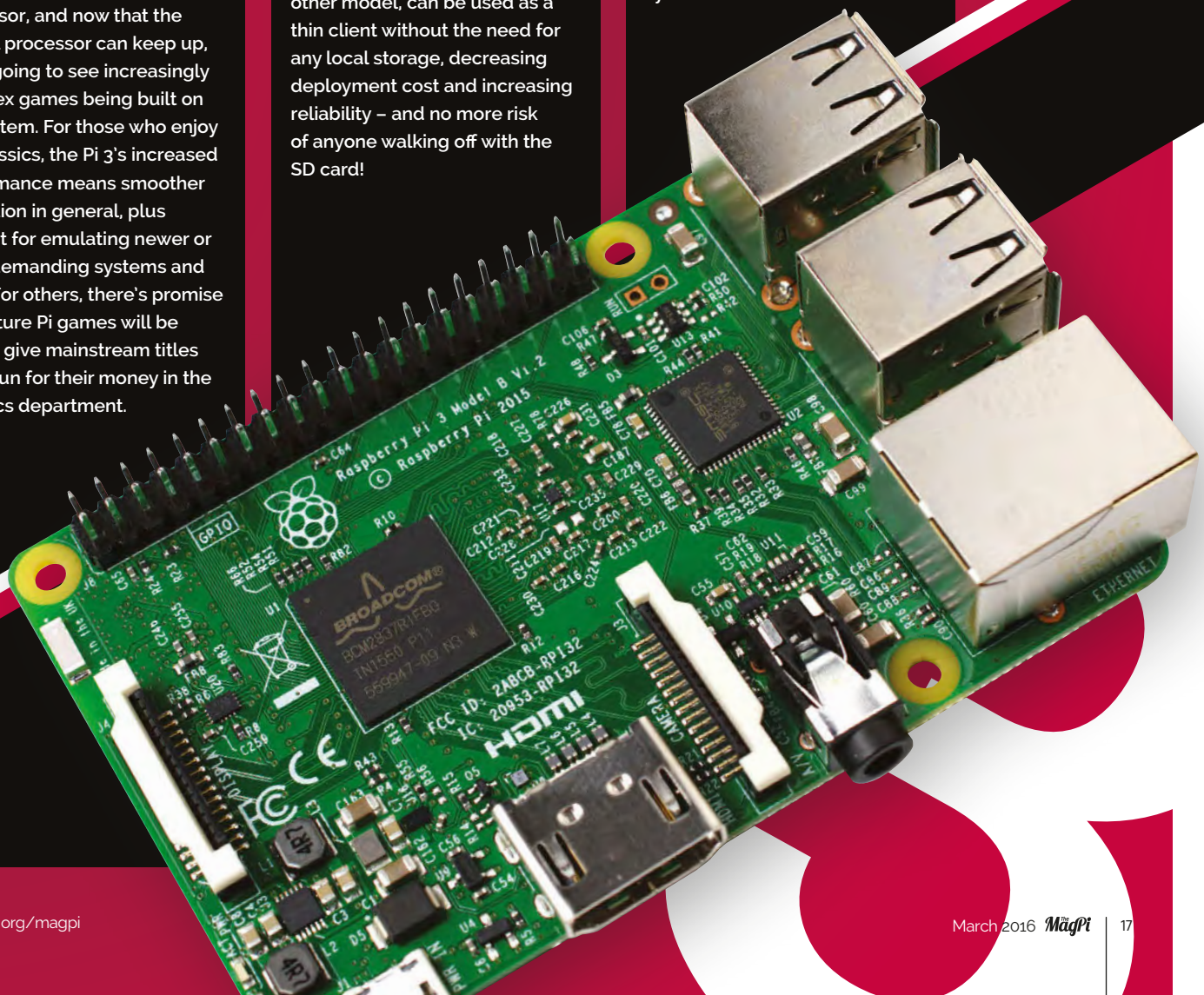

# GET YOUR PI 3 FIRST

WITH THE MAGPI & THE PI HUT

There are much more than just savings on offer for print subscribers of the magazine. Here's how you can get your Pi 3 first...

On 29 February we sent all print subscribers an email containing a special code for use at [ThePiHut.com](http://ThePiHut.com) to enable them to be among the first people in the world to receive a Raspberry Pi 3. If you didn't get a code or aren't yet a subscriber, you've got until 13 March to subscribe and make use of this very special offer...

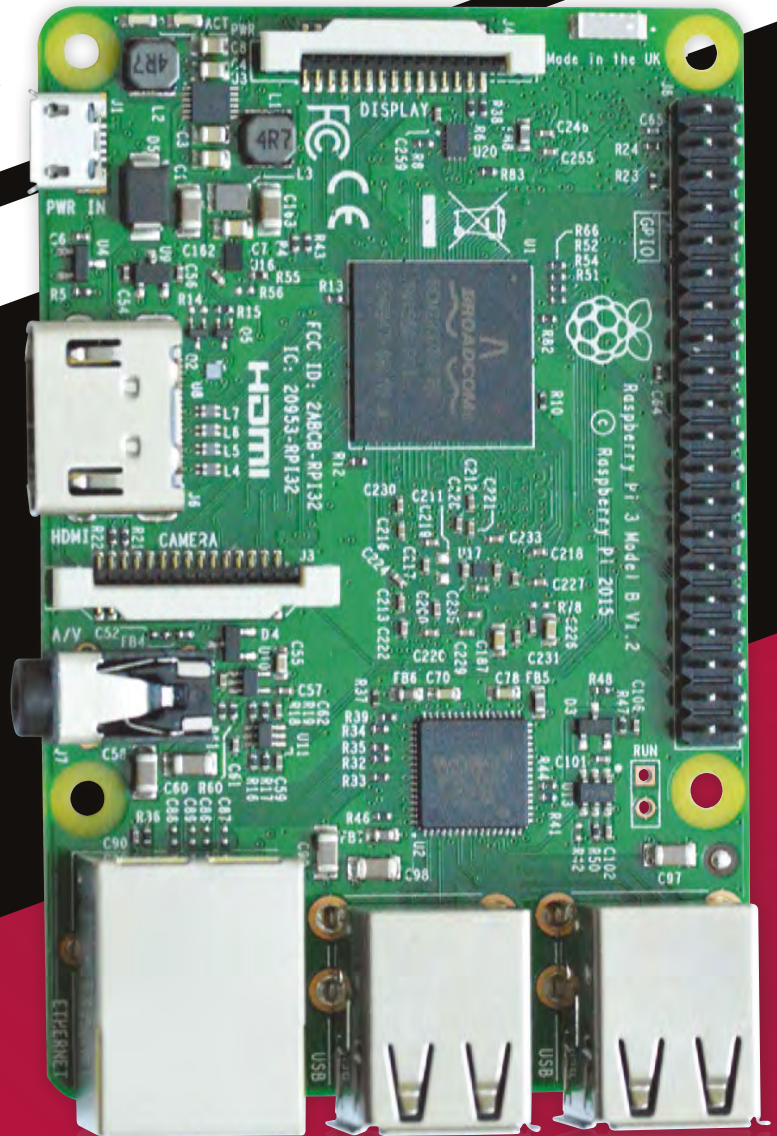

## HOW TO USE YOUR CODE



The **PiHut**  
www.ThePiHut.com

Use your subscriber code at The Pi Hut to:

- Jump to the front of the queue
- Get priority handling of your Pi 3 order
- Be first in line if stock is short

- **FIND YOUR EMAIL FROM THE MAGPI**  
The email was sent to all subscribers on 29 February from [magpi@raspberrypi.org](mailto:magpi@raspberrypi.org)

- **GRAB YOUR SUBSCRIBER CODE**  
Make a note of your unique code or copy it from the email

- **VISIT THEPIHUT.COM**  
Visit [thepihut.com](http://thepihut.com) and put a Pi 3 in your basket

- **ENTER YOUR UNIQUE SUBSCRIBER CODE**  
Simply paste or write-in your code at the checkout

## NO CODE?

If you're an existing subscriber and you didn't receive an email, it might be because your address isn't in the subscriptions database. To rectify this simply email [magpi@selectps.com](mailto:magpi@selectps.com) with your full name and postcode and our subscriptions team will reply with your unique code within 24 hours.

Not a subscriber? It's not too late to make use of this offer. Simply subscribe (over the page) and email [magpi@selectps.com](mailto:magpi@selectps.com) requesting your unique subscriber code before 13 March to make use of this fantastic offer.

# SUBSCRIBE TODAY!

Subscribe to the Official Raspberry Pi mag today for a whole host of benefits

## Subscription benefits

- Save up to 25% on the price
- Free delivery to your door
- Never miss a single issue
- Get it first (before stores)

**PI ZERO  
#40 IS STILL  
ON OFFER  
Call today!**

SAVE  
UP TO  
**25%**



# SUBSCRIPTION FORM

YES! I'd like to subscribe to The MagPi magazine & save money

This subscription is:  For me  A gift for someone\*

Mag#43

## Pricing

Get six issues:

£30 (UK)

£45 (EU)

\$69 (USA)

£50 (Rest of World)

Subscribe for a year:

£55 (UK)

£80 (EU)

\$129 (USA)

£90 (Rest of World)

Direct Debit

£12.99 (UK) (quarterly)

## How to subscribe:

- [magpi.cc/Subs1](http://magpi.cc/Subs1) (UK / ROW)
- [imsnews.com/magpi](http://imsnews.com/magpi) (USA)
- Call +44(0)1202 586848 (UK/ROW)
- Call 800 428 3003 (USA)

Available on the  
 App Store

GET IT ON  
 Google Play

**YOUR DETAILS** Mr  Mrs  Miss  Ms

First name ..... Surname .....

Address .....

Postcode ..... Email .....

Daytime phone ..... Mobile .....

\*If giving The MagPi as a gift, please complete both your own details (above) and the recipient's (below).

**GIFT RECIPIENT'S DETAILS ONLY** Mr  Mrs  Miss  Ms

First name ..... Surname .....

Address .....

Postcode ..... Email .....

### PAYMENT OPTIONS

**1 DIRECT DEBIT PAYMENT** £12.99 every 3 issues (UK only)  
Instruction to your bank or building society to pay by Direct Debit



Please fill in the form and send to:

The MagPi, Select Publisher Services Ltd,  
PO Box 6337, Bournemouth BH1 9EH

Service user number

Name and full postal address of your bank or building society:

To: The Manager Bank/building society .....

Address .....

Postcode .....

Name(s) of account holder(s) .....

Branch sort code  Account number

Reference  (Official use only)

#### Instruction to your bank or building society

Please pay Select Publisher Services Ltd Direct Debits from the account detailed in this instruction subject to the safeguards assured by the Direct Debit Guarantee. I understand that this instruction may remain with Select Publisher Services Ltd and, if so, details will be passed electronically to my bank/building society.

Signature ..... Date

Banks and building societies may not accept Direct Debit instructions for some types of account.

### SUBSCRIPTION PRICING WHEN PAYING BY CHEQUE OR CREDIT/DEBIT CARD

6 ISSUES  UK £30  Europe £45  Rest of world £50

12 ISSUES  UK £55  Europe £80  Rest of world £90

### 2 CHEQUE

I enclose a cheque for ..... (made payable to Select Publisher Services Ltd)

**3 CREDIT/DEBIT CARD**  Visa  MasterCard  Maestro  Switch

Card number

Expiry date

Valid from  (if shown)

Issue number  (if shown)

Security number

(last 3 digits on the back of the card)

Signature ..... Date

I would like my subscription to begin from issue ..... (month + year)

#### RETURN THIS FORM TO:

MagPi Magazine Subscriptions, Select Publisher Services Ltd, PO Box 6337,  
Bournemouth BH1 9EH

Please tick this box if you DO NOT want to receive any other information from Select Publisher Services Ltd.

Please tick this box if you DO NOT want to receive any other information from other companies.

Please tick this box if you DO NOT want to subscribe to The MagPi newsletter.



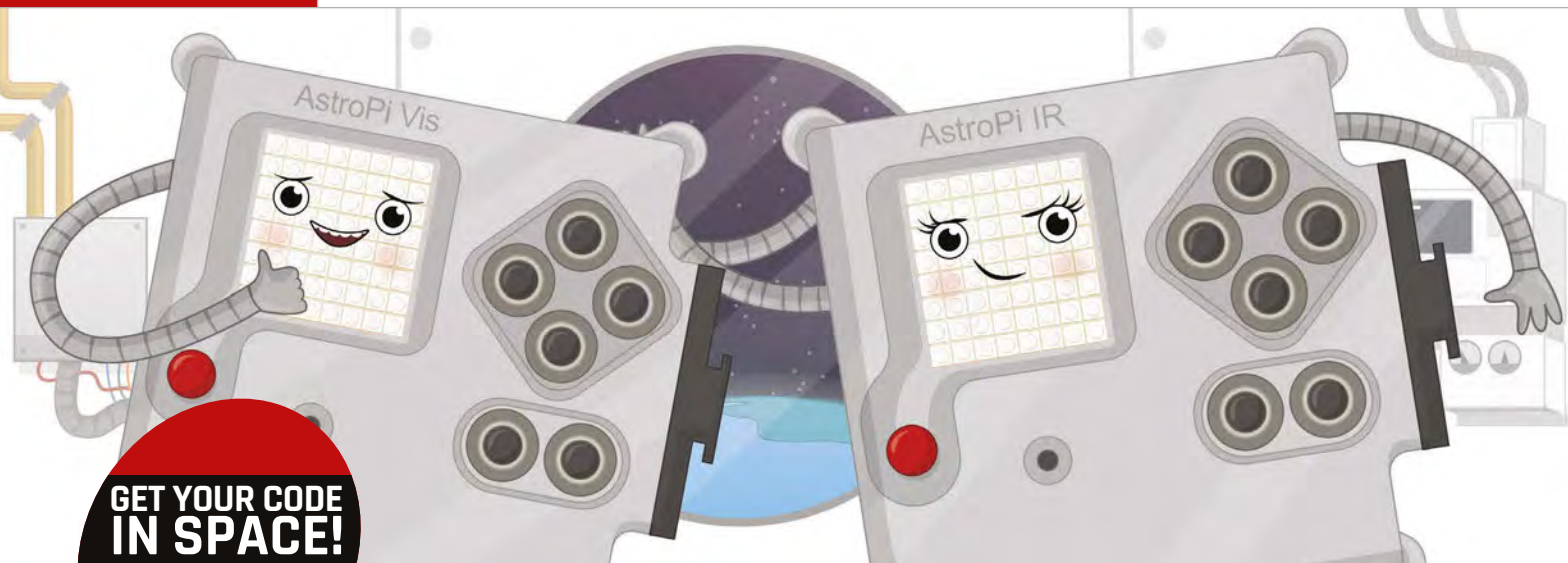

**GET YOUR CODE  
IN SPACE!**

Find out more about  
the new coding  
competition  
on **page 24!**

# ASTRO PI: SWITCH ON!

Ed and Izzy are finally up and running on the International Space Station: what have the Astro Pis been up to so far?

**W**hile the two Astro Pis were launched in early December last year, they have until recently been sitting aboard the International Space Station, waiting to be turned on. It wasn't until January that the first Astro Pi was even unpacked.

Due to the astronauts' busy, tightly organised schedules and all the precautions and regulations

aboard the ISS, even the switching on of the computers was planned as part of the schedule. After some minor delays requiring Tim to perform a spacewalk, Ed was booted up on 2 February 2016 and began his first experiment.

There was excitement online and at the Raspberry Pi offices as the Astro Pi was finally turned on; a Twitter conversation taking place between Tim and the

freshly woken Ed confirmed that switch-on was successful.

The Crew Detector code was settled on as the first long-term experiment. This program was created by Cranmere Code Club from Cranmere Primary School and ran for a whole week, measuring humidity in the capsule to try to detect whether or not one of the crew members had entered the European Columbus module where it was currently

## THE MISSION SO FAR...

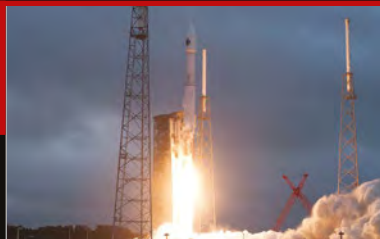

**Astro Pi launch**  
**6 December 2015**

The two Astro Pis are launched into space from Cape Canaveral in Florida, on a course for the ISS.



**On the ISS**  
**9 December 2015**

After a few days in space, the Astro Pis finally arrive at the ISS, where they wait to be unpacked.



**Tim goes to space**  
**15 December 2015**

Astronaut Tim Peake blasts off into space with his team, ready to start his mission aboard the ISS.



THE STORY OF ASTRO PI (PART 1)

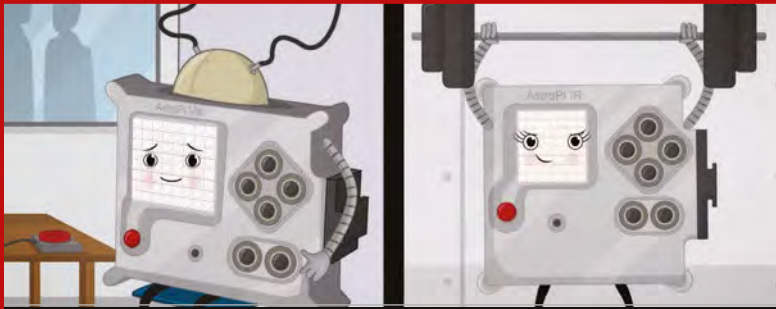

Want to keep up with the adventures of Ed and Izzy in a more colourful format? Their tale is being told through several parts in the cartoon series, *The Story of Astro Pi*. Part one is already up and ready for everyone to watch on the Astro Pi website; you can watch it here: [magpi.cc/1PCaxJ4](http://magpi.cc/1PCaxJ4)

situated. If a pre-specified change in humidity was detected, it would ask for any crew around to confirm they were in the capsule.

Ed will be running several other experiments during Tim's mission on board the ISS. Immediately after Crew Detector finished, Ed started running SpaceCRAFT, a *Minecraft*-themed experiment.

To get a glimpse into how busy the astronauts are on board, prompting this delayed switch-on, you only need to look at the weekly blogs revealing Tim's exploits on the ISS. For the week of the Astro Pi switch-on, he'd removed a shutter door on the ESA's Biolab, replacing it with a cover that allowed the unit to begin more experiments. He filled out questionnaires on his 'space headaches' and did testing on his skin; remember, along with other experiments, each astronaut is themselves an experiment on how well humans can survive living in space.

Before switching on the Astro Pi, Tim worked on the airlock in the Kibo laboratory. He then followed up the switch-on by talking to UK schoolkids and attending his weekly medical. The list goes on, with more work in Kibo throughout the week, loading up the Cygnus cargo craft before it leaves, and helping his fellow crewmates with a spacewalk.

It's a busy life for an astronaut, and, as everything in space is said to take three times longer than normal, it can't all be done as quickly. So, after a very busy two weeks on board the ISS, it was finally time for Izzy to be turned on.

Izzy had been waiting for the Cygnus space capsule to leave the ISS, as it was blocking the porthole that she would be using to look down on the Earth for her experiments. With the capsule's departure, she was finally unpacked and booted up on 16 February 2016. To begin with



Left Tim and Ed converse via Twitter to make sure Ed has turned on properly. Izzy booted up a couple of weeks later

she'll be running Flags, code from Space-Byrds of Thirsk School that shows the flag of the country the ISS is currently flying over.

So, after over a year of planning and coding, the Astro Pis are both finally operational, running schoolkids' code on Raspberry Pis orbiting the Earth. Hopefully, we'll start getting data soon so we can see just what results the programs are producing.



**Unpacking the Astro Pis**  
4 January 2016

Ed is set up in the ISS at his designated spot, ready and waiting to be turned on.



**Ed boots up**  
2 February 2016

Ed gets switched on by Tim Peake and starts running Crew Detector as his first experiment.



**Izzy switches on**  
16 February 2016

Finally, Izzy is activated by Tim and begins her experiments, pointing her camera at the Earth far below.

# WHAT ARE ED AND IZZY UP TO?

Each Astro Pi has a separate mission. What are they?



## ED THE ASTRO PI VIS

Performing experiments with the crew and on the environment of the ISS. Follow Ed on Twitter @astro\_pi\_vis



### Experiment: SpaceCRAFT

**Coder:** Hannah Belshaw,  
Cumnor House Girls' School

Taking data from the Astro Pi's sensors, Hannah's code visualises the information in *Minecraft*. Columns of specific blocks represent different environmental measurements, and a blocky model of the ISS is used to represent movement and orientation.



### Experiment: Reaction Games

**Coder:** Team Terminal,  
Lincoln UTC

A suite of reaction games with a little Sense HAT-optimised interface that records astronauts' response times over a set period, to investigate how reaction times change during prolonged space flight.



### Experiment: Radiation

**Coder:** Arthur, Alexander, and Kiran,  
Magdalen College School

A very clever use of the camera module, this code detects space radiation over a period of time, to measure the intensity and level of radiation. It does this by first having the camera lens blanked off to prevent normal visible light from being recorded. However, this doesn't stop high-energy radiation being detected; this will cause specks of light, which are then recorded.



## IZZY THE ASTRO PI IR

Staring out at the planet she came from, Izzy will be taking pictures of Earth. Follow her on Twitter @astro\_pi\_ir



Izzy is equipped with a Pi NoIR Camera Module, allowing her to see infrared light. This makes her uniquely suited to run the Trees code by the Enviro Pi team of Westminster School. Pictures will

be taken of the ground using the IR camera as Izzy orbits the Earth, staring out of the ISS's window. Using a special 'false colour' image processing technique, a Normalised Differentiated Vegetation Index (NDVI) can be ascertained which measures the health of plants. This processing occurs on the ground after the pictures have been taken.

## NEW CODING COMPETITION!

Missed your chance to get your code in space? Enter the 2016 Coding Challenge

While the two Astro Pis already contain code from several schoolchildren, there's now a chance for others to send up more code to run on Ed and Izzy!

If you want to get involved, there are two challenges you can take part in. The first is to create an MP3 music player in Python to run on one of the Astro Pis. The second challenge is to actually create some music to play on the music player using Sonic Pi.

You can find out more information on how to enter on the Astro Pi website: [magpi.cc/AstroPiChallenge](http://magpi.cc/AstroPiChallenge).

You'll need to hurry, though: entries must be received by 31 March 2016!

- The files allow you to print an almost exact replica of the Astro Pi case on the ISS
- The port for the Sense HAT LED matrix and joystick are usable in the build
- You can even fit in the same push buttons used in space, although they are a little pricey
- You can have it printed in any colour, and even sand it down for smoothness



# MAKE YOUR OWN ASTRO PI!

Perform experiments that are out-of-this-world with a 3D-printed Astro Pi case and a Sense HAT

Want to make an Astro Pi at home? Now you finally, properly can, thanks to the official 3D-printable Astro Pi flight case! While it may not be milled out of aluminium or weigh as much as the original, it functions in exactly the same way as the version in space. It lets you view the LED matrix on the Sense HAT, use the joystick, and even add some buttons. For people taking part in the new Coding Challenge, it's also a good way to test out your code on a unit like the one Tim has up on the ISS.

## HERE'S SOME YOU MADE EARLIER...

People were quick to start creating their own Astro Pis. Here are some of our favourites



Recreating Tim Peake's famous (in the Pi community) pose, the young space cadet and occasional *MagPi* writer Jasper Hayler-Goodall holds his silver version proudly

Alan McCullagh's mini Astro Pi case is no larger than a Raspberry Pi Zero. If only there was a Sense HAT Zero

Alan McCullagh @stytower  
 Have printed off "mini" @astro\_pi flightcase to see what it's like=0) #NeedABigger3DPrinter  
[raspberrypi.org/learning/3d-pr...](http://raspberrypi.org/learning/3d-pr...)

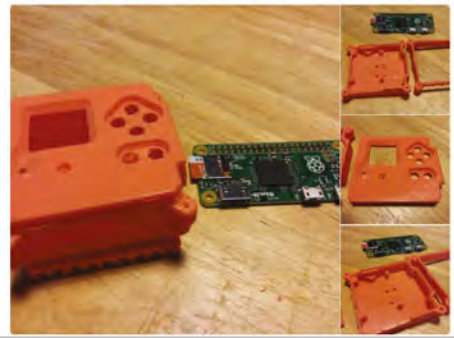

## DO SCIENCE WITH YOUR ASTRO PI EXPERIMENT WITH THE SENSE HAT!

You've got your Astro Pi: so what do you do now? Experiment! The Sense HAT was designed to sense its environment, which allows it to perform many types of experiments. If you're not sure where to start, why not have a look at our new book, *Experiment with the Sense HAT!* We tell you how to get started with this neat Pi add-on and how to use every function, before giving you several cool projects to try out that make full use of the Sense HAT.

The book is available digitally via our app for only £2.99, or you can get the brand new print version for £3.99! Check out our website for more details:

[magpi.cc/Sense-HAT-book](http://magpi.cc/Sense-HAT-book)

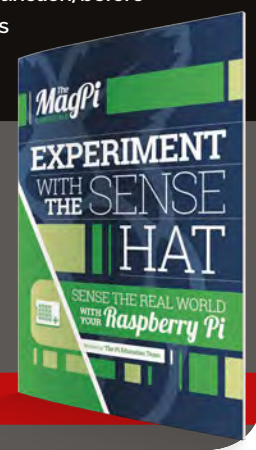

# RASPBERRY PI ZERO PRODUCTION GETTING ON TRACK

First-party hardware production leads to scaling challenges

**T**he launch of the Raspberry Pi Zero, the world's first fully functional microcomputer to cost just £4/\$5, caused quite a stir. Unsurprisingly, given the precedent of the Foundation's other launches, initial stock sold out within minutes. What has been more surprising is that stock continues to be elusive, with small batches appearing in the official sales channel only to immediately disappear again under a flood of demand.

The scarcity of the Pi Zero has led to a 'black market' of sorts appearing. When we gave away a cover-mounted Zero with issue 40, we were disappointed to see auction sites filled with opportunists trying to profit from purchases from supermarket shelves.

Even now, there are unscrupulous outlets looking to profit from the high demand for the device. Some retailers have taken to buying up stock from the official outlets in

order to resell at a substantial mark-up; one seller was recently found to be adding a pair of cheap adaptor cables to the Pi Zero in order to attempt to justify a £36 selling price.

Buyers are disappointed that they can't easily get their hands on one or more Pi Zeros for their planned projects, and doubly so when they see rampant

Foundation co-founder Eben Upton explained during an interview in early February. "It'd be good to get to a point where we're doing at least 50,000 a month for Zero. I think we could do 50,000 a month on Zero pretty comfortably."

But, given the tradition for new Pi models to sell out at launch, why is it taking so long to ramp up production on the Zero? The

**“**There's light at the end of the tunnel: production is being ramped up to meet demand **”**

profiteering. Fortunately, there's light at the end of the tunnel: production is being ramped up to meet demand.

"I placed another 150,000 POs [production orders] – well, a pair of POs, a 50K and a 100K – in the last couple of days," Raspberry Pi

answer lies in the board's unique position, Eben reveals. "This isn't quite the same as the other Pis, because the other Pis are made by RS and Farnell. We make these Pis, so you're actually looking at a small company trying to scale."

"We've got good resources and good engineers, but you're looking at a small company trying to scale production," Eben continues. "It's not quite realistic to compare the [Pi Zero] throughput to the throughput of the big Pis, because the big Pis are being made by billion-dollar, billion-pound companies; the Zero's being made by us."

The launch of the Pi 3 won't see the Zero put on the back-burner, though. "If we can get it stable at 50,000 a month," Eben promises, "then we can look at how we can scale up from that."

**Below** Production scaling has proven a challenge for the Raspberry Pi Foundation's first in-house board, the Pi Zero



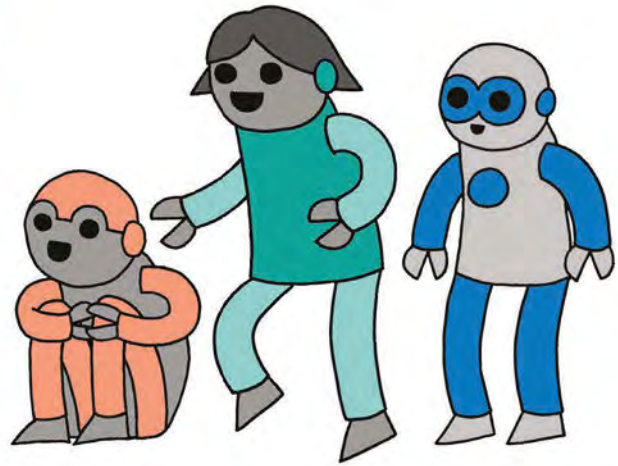
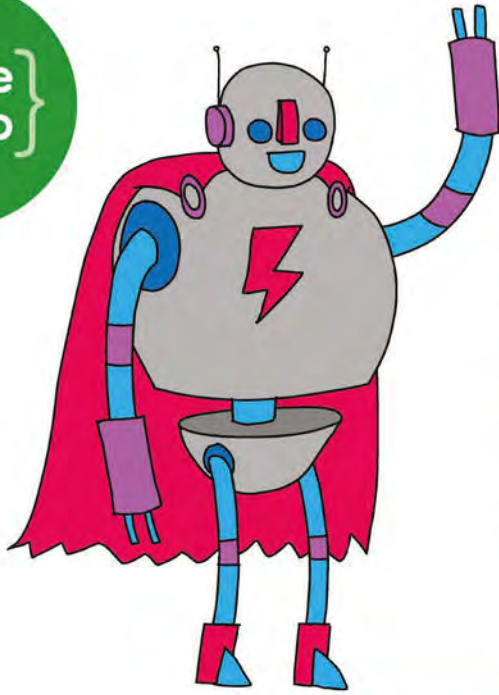

Can you help inspire the next generation of coders?



**Code Club** is a nationwide network of volunteer-led after school clubs for children aged 9-11.

We're always looking for people with coding skills to volunteer to run a club at their local primary school, library or community centre for an hour a week.

You can team up with colleagues, a teacher will be there to support you and we provide all the materials you'll need to help get children excited about digital making.

There are loads of ways to get involved!

So to find out more, join us at [www.codeclub.org.uk](http://www.codeclub.org.uk)

# RASPBERRY PI RIDES A WHALE

The award-winning Raspiwhale project features a Pi-powered tracking device attached to a whale. We chat to its designer, **Daniel Pérez Martínez**

## A SEAFARING PI



Since the Raspiwhale is designed to be attached to a marine mammal, it features a waterproof case to protect the electronic components inside. As an extra precaution, the Raspberry Pi Model A+ itself has its connections sealed with a special resin. Two 3200mAh Li-Po batteries power the Pi and an XBee radio transmitter. The watertight container is attached to a base with three suction cups for mounting on the whale's back. At the end of a session, the suction cups are vented to release the device, which floats to the surface to be recovered by the team.

**A**re there any places left to which the Raspberry Pi is yet to venture? Even the sky is no limit, with two Astro Pis having rocketed to the International Space Station. Back on planet Earth, the Pi is exploring new depths as it dives towards the seabed of the South Atlantic... mounted on the back of a whale!

As well as being one of the most extraordinary Pi projects we've encountered, Raspiwhale ([magpi.cc/1O1ozSs](http://magpi.cc/1O1ozSs)) has a serious scientific purpose: to research the behaviour of southern right whales (*Eubaleana australis*) around Península Valdés, Puerto Madryn, Argentina.

The Raspberry Pi is a recent addition to this long-running research project. "Around ten years ago, I was the leader of the research team to explore reactions of whales to vessels at harbours and bays,"

explains Raspiwhale creator Daniel Pérez Martínez. "I needed a device that would allow me to measure the behaviour of the whale, and knew that they were developing instruments of this kind in the United States. The problem was that they were in the experimental stage or were very expensive - over \$20,000." This led the team to think about creating their own devices. Since the Raspberry Pi hadn't yet been launched, the first attempt involved a Gumstix board, without success; this was followed by the use of simple data loggers.

When the research project was continued as a doctoral thesis of Belen Arguelles - at the laboratory of applied ecophysiology of CENPAT-CONICET directed by Dr Marcelo Bertellotti - Daniel offered to develop a new device. "Exactly a year ago I discovered the Raspberry Pi world," he tells us, "and I turned fully to developing ideas. Of course, Raspiwhale was the priority."

## A watertight solution

The Raspiwhale 1 (RW1) unit comprises two main parts: a base equipped with suction cups to stick to a whale, with a float to enable subsequent recovery from the sea, and a watertight container to house all the electronic components. The latter includes a Raspberry Pi Model A+, two LiPo batteries, sensors, XBee transmitter, hydrophone, and HD camera.

The RW1 took Daniel six months to research and develop. Fortunately, he had a head start since the team already had six years' experience of using a similar sealed

A long carbon-fibre pole is used to place the RW1 on the back of a whale





The orange RW1 is clearly visible on the back of this whale in the bay of Puerto Madryn

container tracking device. Compared with previous efforts, he says it was “extremely quick and simple development work with Raspberry Pi.” It also offered a greater range of possibilities: “It was much more than we had imagined, and at very low cost.”

While there are numerous devices available for monitoring wildlife behaviour, using technology such as VHF telemetry or the Argos system, the Raspiwhale is the first to feature a fully functional computer with an operating system. According to Daniel, there are three key advantages of having a Raspberry Pi on board: low cost, ease of use, and the ability to use multiple sensors simultaneously. “The huge amount of information online, forums, and the Raspberry Pi community makes [for] easy implementation of complex sensors, storage, analysis and downloading of data, and so on.” In addition, the Pi’s GPIO connection and large number of protocols make it easy to implement “ideas for measuring environmental aspects, whether [about an] animal or its environment.”

While the RW1’s IMU (inertial motion unit) tracks a whale’s movements (including speed, rotation, and compass bearing) with great accuracy, the inclusion of the Pi enables the collection of a wide range of key data, such as temperature (whale and sea), darkness, photosynthesis activity, whale heart rate, muscle activity, swimming patterns, and indicators of stress. An attached HD camera captures often dramatic video footage and stills.

## Testing times

So far, two RW1 models have been built and field-tested: they are required to work at depths of up to 100m and survive collisions with animals weighing 40 tons. Each device is placed on a whale – attached with non-invasive suction cups, so as not to harm the animal – using a long carbon-fibre pole extended from a boat. As well as transmitting its position, the RW1’s XBee radio module enables two-way communication with a remote human operator who can set each of the sensors and download data, videos, photos, and sound recordings.

Daniel tells us the system is already producing some positive results. “In tests, we could record dives of a mother with her cubs, [monitor] behaviour of reproduction and feeding, [and record] vocalisation with the hydrophone and video simultaneously.” In 2016, the team plan to use Raspiwhale to record at least 30 sessions of diving and situations involving interaction between whales and boats.

Much to Daniel’s surprise, the project has already attracted the interest of other wildlife research teams around the world: due to its use of low-cost hardware and open-source software, other researchers could easily adapt the device for their own purposes. Meanwhile, Daniel is planning to develop a smaller version of Raspiwhale to use on dolphins, and reckons the tiny Pi Zero opens up some interesting new possibilities.

## IDEAS PI



Daniel’s Ideas Pi website ([ideaspi.com](http://ideaspi.com)) lists numerous planned projects using the Raspberry Pi, ranging from a weather station to a metal detector. He tells us that his next goal is the development of a water level/quality measurement station for the mining industry. “The idea is that both mining companies and partner communities can develop their projects to have low-cost workstations, networked to monitor the quantity and quality of water, as it changes over time, in regions where mining takes place.”

## INNOVATION AWARD



In October 2015, Raspiwhale won first prize in the category ‘New technologies in scientific research’ at Argentina’s prestigious Innovar event – a government-backed annual innovation competition that featured entries from over 1,300 projects in 2015. The award was presented to a delighted Daniel Pérez Martinez (left), Dr Marcelo Bertellotti, and Belen Arguelles.

# YASMIN BEY

## DIGITAL GIRL OF THE YEAR 2015

How a young computer hobbyist discovered the Raspberry Pi and won a European award for computing in the same year...

**W**hen you're a kid, you have to make the difficult choice of what kind of career you want to go into without really having the life experience necessary to properly choose what you'd like to do. For Yasmin Bey, a Year 10 student doing her GCSEs, the decision is not that tough.

"Probably an AI specialist. It's definitely a field I would like to go into," Yasmin confidently tells us. That's her second choice after starting her own business as well – one in the tech and computing sector. Even at 15,

she's already experienced enough with computing to know it is what she loves, and her efforts have been rewarded by winning the prestigious Digital Girl of the Year award for 2015.

"It was really, really cool. So cool," Yasmin says of winning the award. "When I heard how many people applied for it – I think it was in the 30,000s – I was amazed. If you do the maths and figure out your chance of actually winning, [the odds] are rather substantial."

Entry was via video where applicants had to answer questions

pertaining to them and their interests in tech and computing. There was also a practical element, according to Yasmin:

"For instance, I showed the skills I learned from my interests in technology... an incomplete Traffic HAT ([magpi.cc/1Mma7oD](http://magpi.cc/1Mma7oD)) and then a complete one, with the soldering, etc. I then did some footage of the robot I made for Pi Wars as well."

By her own admission, she feels the video was cringeworthy (don't we all when we make videos of ourselves?). It did, however, win her the prestigious award.

Yasmin's interest in computing started incredibly early, around the age of four or five, when she decided to make a website:

"I kind of liked that on a website you have the power to put whatever you want on it, so I just decided to make my own. It had really ugly marquee tags and Comic Sans. From there, though, I learnt that there are more languages than just HTML and CSS, and then began making JavaScript sites."

At that age, she was unable to learn more from school – "I don't think school knew what HTML was!" – so the next best place was learning on YouTube. A prime

### DIGITAL GIRL OF THE YEAR

**AWARD MISSION:**  
Recognising outstanding girls in digital sectors around the world

**REGION:**  
Europe

**PART OF:**  
The Ada Awards, a global award network named after computing pioneer Ada Lovelace

**WEBSITE:**  
[digitalgirlaward.com](http://digitalgirlaward.com)

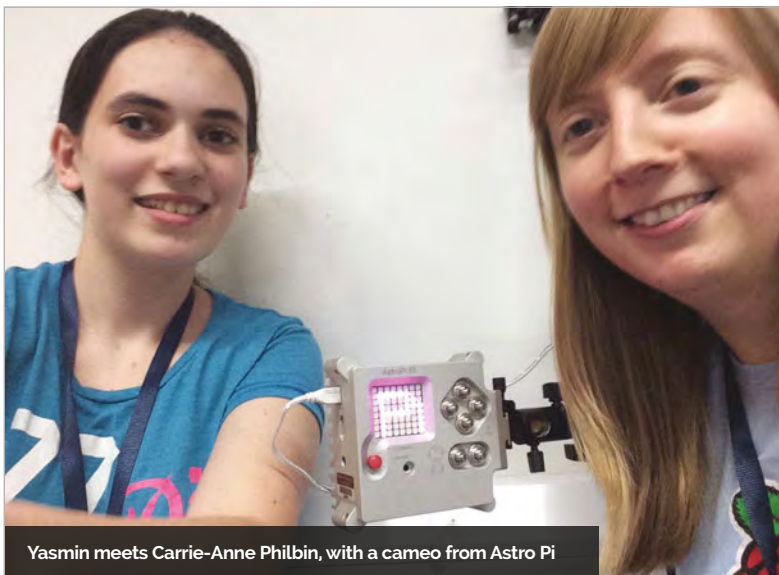

Yasmin meets Carrie-Anne Philbin, with a cameo from Astro Pi



## MULTI-AWARD WINNING

As well as winning Digital Girl of the Year, Yasmin has been nominated for the 2016 FDM everywoman in Technology Awards. These awards are for women who are role models in the tech sector, showing that women work in STEM industries too, as a way to inspire young girls and women to keep on with STEM subjects if they want to. Yasmin is a finalist for the One To Watch award, among other school and university students. Clearly, the rest of the world is beginning to take notice of Yasmin and her abilities.

every  
woman  
in  
TECHNOLOGY AWARDS

The robot Yasmin entered in Pi Wars December 2015, less than a year after getting a Raspberry Pi

learning resource for kids now that wasn't available even 15 years ago, the video hosting site enabled Yasmin to learn Python from watching educational videos.

Despite being so well known in the Raspberry Pi community, and winning this award in part thanks to her experiences with the Pi, Yasmin only got her first Raspberry Pi in February 2015.

"I heard about it through school," she recalls. "That's an amazing story about how I found out about it actually. I was helping my friend with their Python homework and their computing teacher posted on their VLE page a link to the Southend Raspberry Jam. It said if you're interested in *Minecraft*, programming, or Raspberry Pis, then come to this. And I thought, I like *Minecraft*, I like programming, what is this other thing?"

After attending the event in November 2014, she decided she wanted to get a Raspberry Pi, but was too late to ask for it for Christmas. Instead she got it for her 14th birthday the following February. As well as making the

it forward with the Wii Remote, then it would move Steve in real-time as well. So as you go forward, Steve would go forward."

Yasmin is a fantastic example of the way that online resources and easier access to coding

" I was amazed... If you do the maths and figure out your chance of actually winning "

robot for Pi Wars that was featured in her application video, Yasmin has been doing a lot of inventive *Minecraft Pi* hacking:

"I had a Raspberry Pi that was streaming to a monitor. It would display where you are in *Minecraft* based on where the connected robot was. So, say, you'd move

tools and hardware can really help teens express themselves and have fun with computing. Her success beyond this is well earned, though, and thanks to it she is currently writing a book as well. We're sure that she will continue to be a success in the years to come.

## MORE TO COME...

Shortly after this issue comes out, Yasmin will be announcing an exciting new product that might pique your interest. We'll be covering it in the magazine next issue, but keep an eye on Yasmin's Twitter feed (@RPI\_Yaz14) if you find yourself feeling a bit impatient to wait that long.

# "HAPPY BIRTHDAY RASPBERRY PI!"

– PI-TOP TEAM

Celebrate Raspberry Pi's  
4th Birthday with  
the Maker's Laptop!

Use discount code

**HAPPYPIDAY**

to receive **free shipping**  
on all **pi-top** laptop  
purchases made on  
14 March 2016.

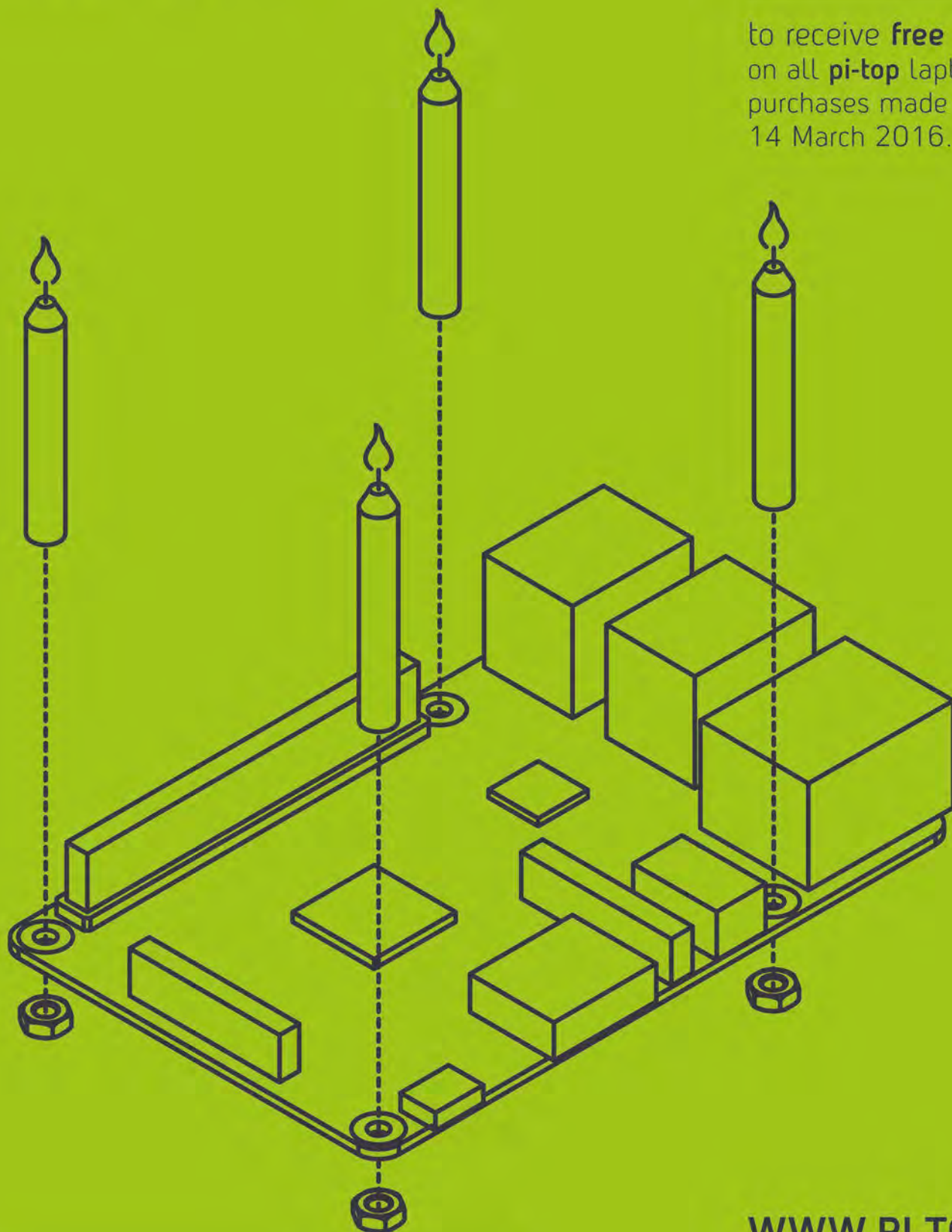

[WWW.PI-TOP.COM](http://WWW.PI-TOP.COM)

# pi-top

AVAILABLE AT  
[WWW.PI-TOP.COM](http://WWW.PI-TOP.COM)

WORLDWIDE SHIPPING  
AVAILABLE IN GREEN OR GREY

World's First Raspberry Pi Laptop.

- 12Hr Battery Life
- 13.3" HD Screen
- Accessable Modular Components & RPi
- Compatible with all models of Raspberry Pi

**\$299** excluding VAT

MagPi Review



---

# pi-topCEED

pi-topCEED is the easiest way to use your Raspberry Pi!

- 13.3" HD Screen
- Front facing access to Components & RPi
- Compatible with all models of Raspberry Pi

**\$99** excluding VAT



"I'd love to see a pi-topCEED  
in every classroom."

— Eben Upton, Founder & CEO of RPi

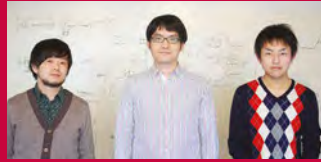

**IDEIN, INC**

Yasuyuki Yamada , Koichi Nakamura and Yukimasa Sugizaki make up the team at Idein, Inc, which works on AI technology.  
[idein.jp](http://idein.jp)

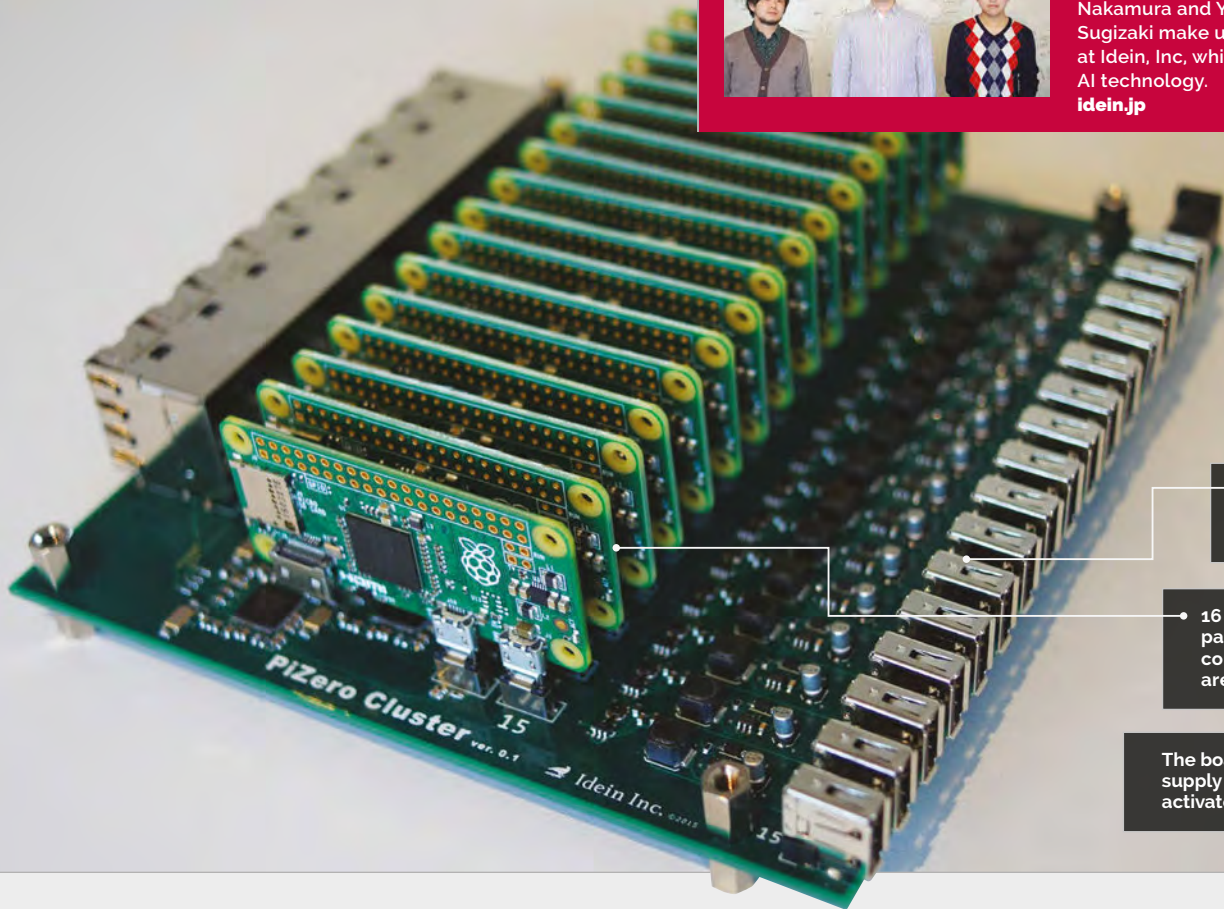

A full-size USB port is wired up to each Pi Zero

16 Pi Zeros working in parallel means 16 1GHz cores and 8GB of RAM are available

The board is powered by one supply on the rear that can activate all 16 Pi Zeros

**Quick Facts**

- ▶ The board works with any number of Pi Zeros
- ▶ From idea to completion, the cluster took six weeks to build
- ▶ A Compute Module is used in the Actbulb
- ▶ The team have been studying the VideoCore GPU for future projects
- ▶ The board is 20cm x 20cm x 5cm, even with Pis attached

# PIZERO CLUSTER BOARD

Turn your Raspberry Pi Zeros into a number-crunching cluster of computers with this custom-made board

**W**hen the Raspberry Pi Zero was being made, Eben Upton mentioned to us how one box of Pi Zeros holds hundreds of them. Hundreds of cores and hundreds of gigabytes of RAM – a crate of power, if used correctly. We never managed to work out the FLOPS one box could theoretically process, even if that might not be feasible. However, a Japanese company also saw the power of the Pi Zero in numbers and has created the PiZero Cluster Board, which allows up to 16 Pi

Zeros to do parallel computing. We spoke to Koichi Nakamura, representative director of Idein, Inc, about the cluster board: “When I was playing with Raspberry Pi Zero, I realised that costs of cables and adapters are relatively expensive, and found a solution that used micro USB plugs for cradles. I used this idea to create our computer cluster... I think it’s useful for many other projects, [but it was] originally designed and developed for our internal purposes.”

Idein is currently developing the Actbulb, a Pi-powered sensor suite that fits into standard lightbulb sockets to use in any way you see fit. Sensors include a microphone and cameras; it’s also internet-enabled and has an audio speaker. “Since we are developing products using Raspberry Pi, we need a cluster of many Pis for software development and tests,” Koichi explains to us. “It’s also useful to set up many other devices... We plan to create a cluster to enable setup of hundreds of our devices a day.”

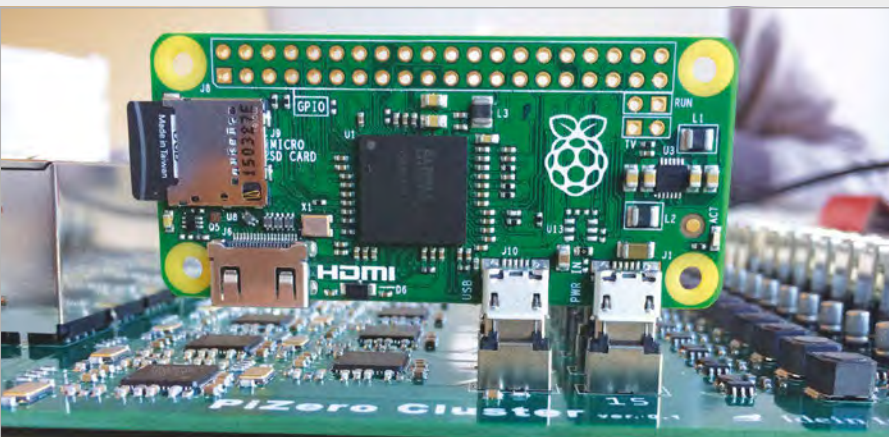

**Above** The Pi Zero is plugged in via its micro USB power and data ports. Each unit also requires an SD card with an operating system installed

**Below** The Pi-powered sensor that necessitated the creation of the Pi Zero cluster board. It attaches to standard light fittings

It's had a huge reaction online, with many people excited by the idea of the board. However, Koichi believes it's quite a simple project:

"PiZero Cluster Board is just a collection of 16 identical circuits. Each circuit draws one Ethernet port and one USB port from [each] Raspberry Pi Zero's micro USB port, using an SMC LAN9512 chip. There are also 16 power supply circuits to generate 5V and 3.3V from a 12V single power source for



**Actbulb**

" We plan to create a cluster to enable setup of hundreds of our devices a day "

Raspberry Pi Zero and LAN9512. All 16 circuits are the same."

With Pi Zeros in short supply, the team were unable to secure enough to complete the cluster at first. Fortunately, we at *The*

*MagPi* managed to call in every favour, pull every string, and beg, plead and borrow to get them the remaining 15 Pi Zeros they needed for tests.

Due to the popularity of the board and its many uses, Koichi plans to put it on Kickstarter once they're ready to crowdfund it. It will be an improved version of the prototype we've seen online.

"In our current plan, the number of Raspberry Pi Zeros and USB ports is reduced to 14," Koichi tells us. "We'll also add an on-board Ethernet switch to the board, and the number of ports is reduced to two." This improvement will reduce the number of Ethernet ports and cables required, and so lower the board's overall cost.



The insides of Actbulb are a lot more complex than a normal light bulb

## CREATE A CLUSTER



### >STEP-01

#### Set yourself up

To start with, all you need to do is slot in your Raspberry Pi Zeros. It works with as few as one and as many as 16 at a time.

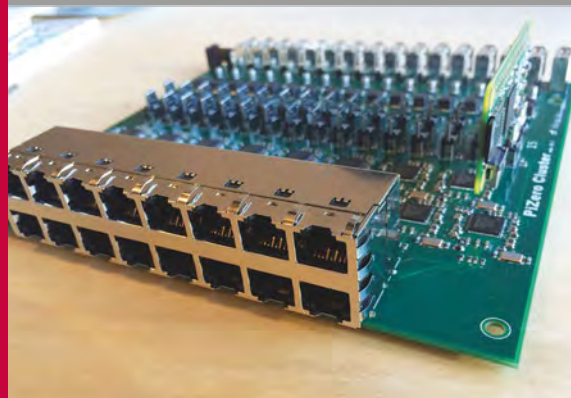

### >STEP-02

#### Hook it up

The next step is to connect it all up. The Ethernet switch and cables should go in first, followed by the AC adapter to power it.

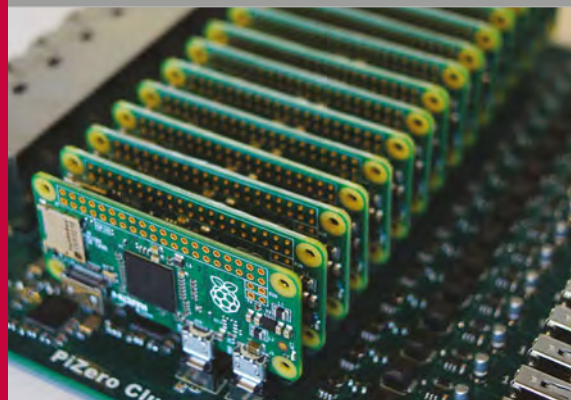

### >STEP-03

#### Work in parallel

That's it! Turn it on and you can program it using MPI or any other methods that utilise multiple Pi Zeros at the same time.



**JEAN GAILLAT**

Jean is a 60-year-old maker from France. He works at Orange Group and is fond of prog rock, electronics, photography, mountain biking, and skiing. [jeangallat.wordpress.com](http://jeangallat.wordpress.com)

# STEAMPUNK PI

This Raspberry Pi reimaged for the 19th century is a wonderful thing. **Lucy Hattersley** talks to its maker, **Jean Gaillat**

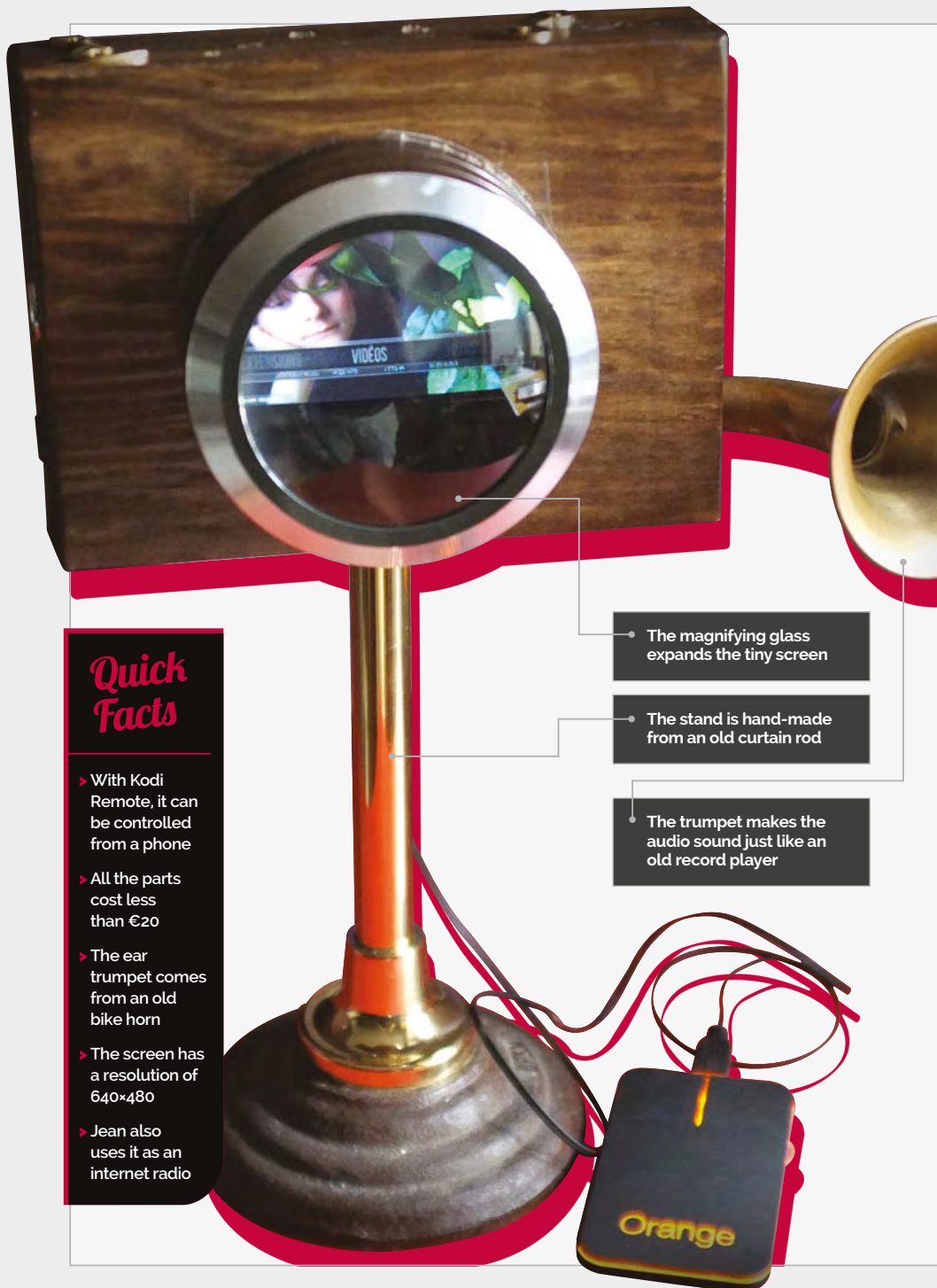

**H**ave you ever wondered what it might have been like if the Victorians had owned Raspberry Pis? Wonder no more, as French maker Jean Gaillat has built this marvellous steampunked Pi that brought his future-retro dream to life. “The Steampunk Pi is my Jules Verne-like mechanism,” says Jean. “I can see my loved one’s pictures or videos [through] a big magnifying glass and listen to very old songs or records through an old ear trumpet. This is the kind of stuff I would have been so happy to find in the attic of my grandparents’ house when I was a young boy. “Steampunk looks good,” he continues. “I don’t know exactly why, but I suspect it has something to do with all the machines I saw in my grandfather’s storeroom – he was a wheelwright.”

The Raspberry Pi is housed inside a wooden box, complete with stand, magnifying glass, and a glorious ear trumpet. “I bought the box for two euros in the Cultura shop near my town,” Jean tells us. (Cultura is a chain of creative workshops in France; [cultura.com](http://cultura.com)). Jean covered the wooden box in Bomb varnish and placed a Raspberry Pi inside. Once the Pi was inside the wooden box, it was time for some accoutrements. “The ear trumpet comes from a very old bike horn,” reveals Jean. “It’s supposed to amplify the sounds coming from a tiny loudspeaker in the box. The

**Quick Facts**

- With Kodi Remote, it can be controlled from a phone
- All the parts cost less than €20
- The ear trumpet comes from an old bike horn
- The screen has a resolution of 640x480
- Jean also uses it as an internet radio

- The magnifying glass expands the tiny screen
- The stand is hand-made from an old curtain rod
- The trumpet makes the audio sound just like an old record player



The Steampunked Pi is a retro device with modern capabilities

## STEAMPUNKING A PI



### >STEP-01

#### Wooden box

The Raspberry Pi is placed inside a wooden box along with a 5V regulator, WiFi dongle, and a small speaker. The Raspberry Pi is running OpenELEC 4.0, and a USB key contains all the media.

sound is exactly what I wanted – just like from an old telephone.”

Jean bought the magnifying glass for 12 euros in a store in Lyon that specialises in devices for camping. “I had seen this glass and said to myself, ‘Oh yeah, that’s just what I want for my Steampunk Pi.’ There were LEDs in it. I pulled out the LEDs and battery and kept the glass. It’s fair to say that this isn’t the kind of screen that’s comfortable

the Steampunk Pi into an artistic object. We particularly like the Victorian stand. “I made it by myself using part of a golden curtain rod,” says Jean. The rod is fixed with screws to an old rusty iron oil lamp support.

“This is a recurring dream,” explains Jean, “to retrieve the very soul of our past, bypassing centuries using a kind of time machine. I have built this thing only to put it somewhere, where it can be found



### >STEP-02

#### Trumpet and stand

An ear trumpet is placed on the speaker to amplify the sound, and a golden curtain rod fixed to an old oil lamp support. On the back of the wooden box is a USB hub.



### >STEP-03

#### Magnified screen

A magnifying glass is fixed to the front of the box, in front of a 4DPI-24-HAT screen from 4D Systems ([4dsystems.com.au](http://4dsystems.com.au)). The result is a quirky player that can be used to view media from an imaginary past.

“ The sound is exactly what I wanted - just like from an old telephone ”

for long shows, but it’s interesting to scrutinise and see my children’s smiling faces through it.”

Obviously, the sound and vision aren’t as good as a high-definition monitor, but it works surprisingly well. “I stare into the glass on the front to watch movies – at one or two metres it’s acceptable,” says Jean.

With the sound and vision up and running, it was time for Jean to turn

by a child in the future. But I have to solve the issue of an empty battery power unit.”

Jean is planning to add speech to the machine next, in his native French of course. “Like [Iron Man’s] J.A.R.V.I.S.,” he says, “talk to the thing and the thing answers: ‘Oui maître. Que puis-je faire pour vous?’ I want to build the internet of talking things: steampunked talking things... waouh!”



The result looks right at home as a piece of art



**KRZYSZTOF JANKOWSKI**

A pixel artist and indie game developer, Krzysztof likes to hack around with Raspberry Pis and Arduino gear in his spare time. [krzysztofjankowski.com](http://krzysztofjankowski.com) / [pix.in](https://www.pix.in)

As the IR range is mostly heat, the sky will be darker than usual, while other objects are highlighted unusually

Take surreal, IR photos during the daytime for a slightly different look at the world

It works roughly like a normal camera – just point and shoot to take a photo!

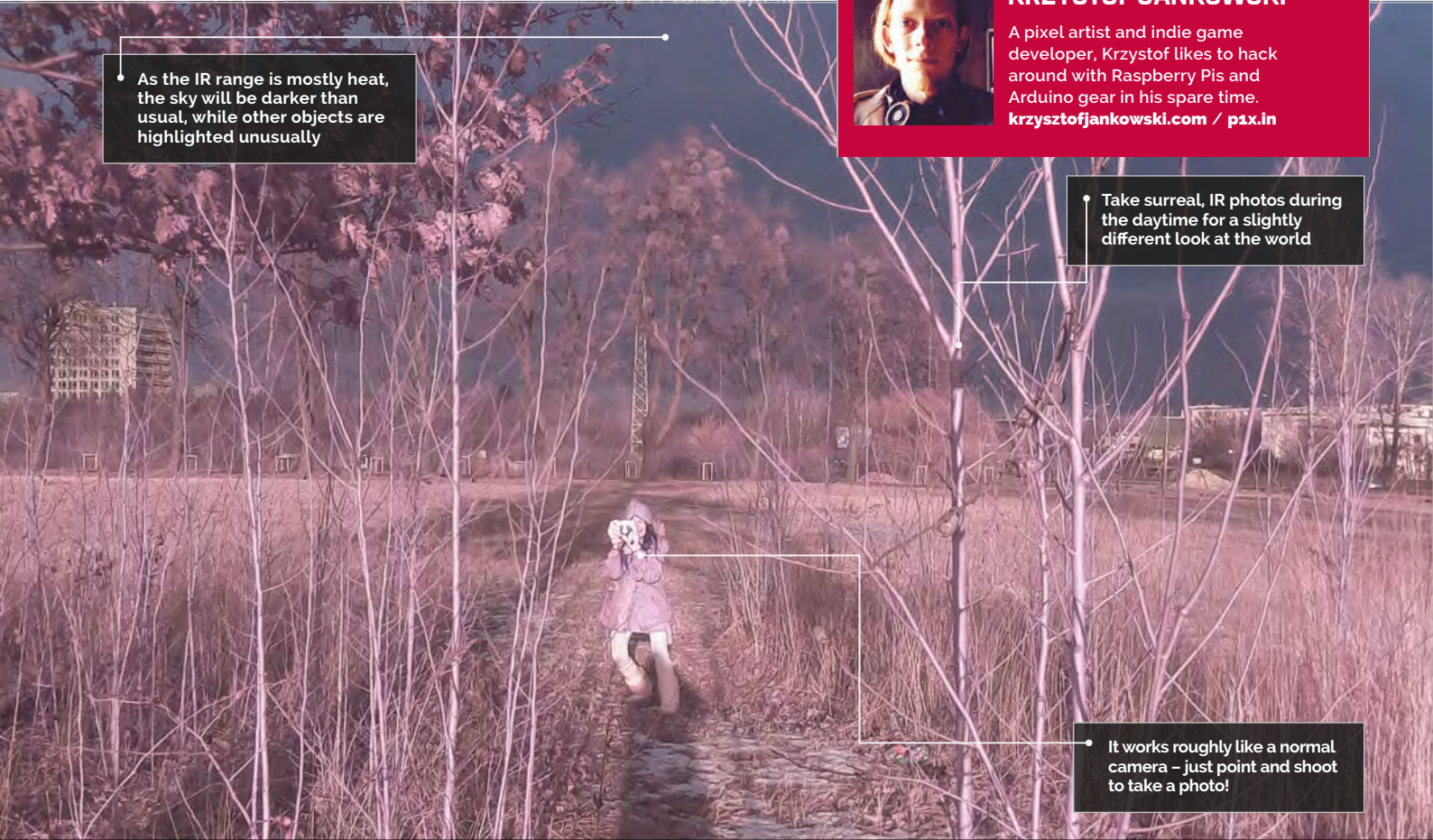

# EYE-PI CAMERA

**Quick Facts**

- ▶ It was tested and completed in a morning
- ▶ Krzysztof likes to make different portable projects using Raspberry Pi
- ▶ Krzysztof plans to make a smart wall with RSS feeds and stats
- ▶ He plans to work with Arch next
- ▶ The project uses a B+ and not a Pi 2 or 3

Never mind a portable Raspberry Pi camera – how about a portable Pi IR camera for taking stunning and unique shots?

**I**nfrared (IR) cameras are traditionally used in low-light situations. Typically, IR is used in security cameras at night, and you can also implant an IR camera into your birdhouse for a live view of some hatchlings. Using it in daytime for ‘normal’ photos, though, is something quite unusual. However, it’s what Krzysztof Jankowski decided he wanted to do using a Raspberry Pi and the Pi NoIR Camera Module. “I’ve been a photographer for many years and I’ve always wanted to take surreal (at least to our eye) infrared photos,” Krzysztof tells us, “but there was no commercial camera that can do that easily. Also, those cameras for astronomers

were always pricey. Using filters was too time-consuming and requires using high ISO. “When I was ready to buy the [Pi] Camera Module, I chose the NoIR to test how it works. After the few first tests, it turned out it works perfectly fine, but using it with wires, monitor, keyboard, and making photos by command line was absolutely not fun. A camera needs to be small and have a physical button to make photos.” Krzysztof made a prototype “using a lot of duct tape” and went for a walk with it. It worked as he’d hoped, so he began work on a more robust and easier-to-use version. “For me it was very easy as I know Linux, programming, and

soldering,” he explains. “I think that even for newbies it will still be easy. The whole thing is fairly basic to make yourself: connect camera, solder button and LED on, put wires to proper GPIO ports, and download my script and install a few required packages.” His custom script is what makes it possible, and is downloadable from GitHub ([magpi.cc/1K2PRgi](https://github.com/magpi/cc/1K2PRgi)). It’s only 23 lines long, but it has some tweaks to the way photos are taken to get them to look the way they do, and to optimise the speed as well, according to Krzysztof: “There’s a small lag like in early digital cameras. For landscape photography it’s absolutely acceptable, though. The only





Glare produces amazing effects when delving beyond the range of visible light into IR

downfall is the booting time: as it boots the whole of Raspbian, it takes 30-40 seconds. However, it can work for hours on my power bank without shutting down.”

Right now, the camera is a little simple, and upgrades are planned for it eventually. Software-wise, Krzystof wants a software shutdown to prevent data corruption, but he also wants to add a small OLED screen

for a live preview and settings. These settings would then be changed with additional switches on the build.

Krzystof has done many little Pi projects himself and doesn't plan to stop here: "I encourage people to experiment with Raspberry Pi – each project is an opportunity to learn something new. And it's always a lot of fun to make something yourself."



The mark two rig has a shutter button and LED to let you know when it's ready, although a preview screen will be added

## TAKE A SURREAL PHOTO



### >STEP-01

#### Boot process

There's no switch just yet, so plugging in the portable battery turns it on. This boots Raspbian on the Pi, and an LED turns on and then off once the camera is ready to go.



### >STEP-02

#### Take a photo

Like with any camera, you just need to press the shutter button. This one activates the Python script to turn the LED on, set the camera up, and take the photo. It then turns the LED off.

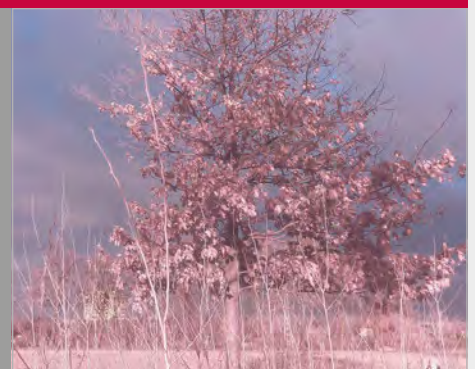

### >STEP-03

#### Get the photo

You could grab the photo off the SD card manually. However, it's set up to be retrieved using SFTP over WiFi as well, for quick access.



**FREDERICK VANDERBOSCH**

Frederick is an electronics hobbyist and software test and integration engineer. One of his recent projects won Element 14's 'Forget Me Not' challenge.  
[frederickvandenbosch.be](http://frederickvandenbosch.be)

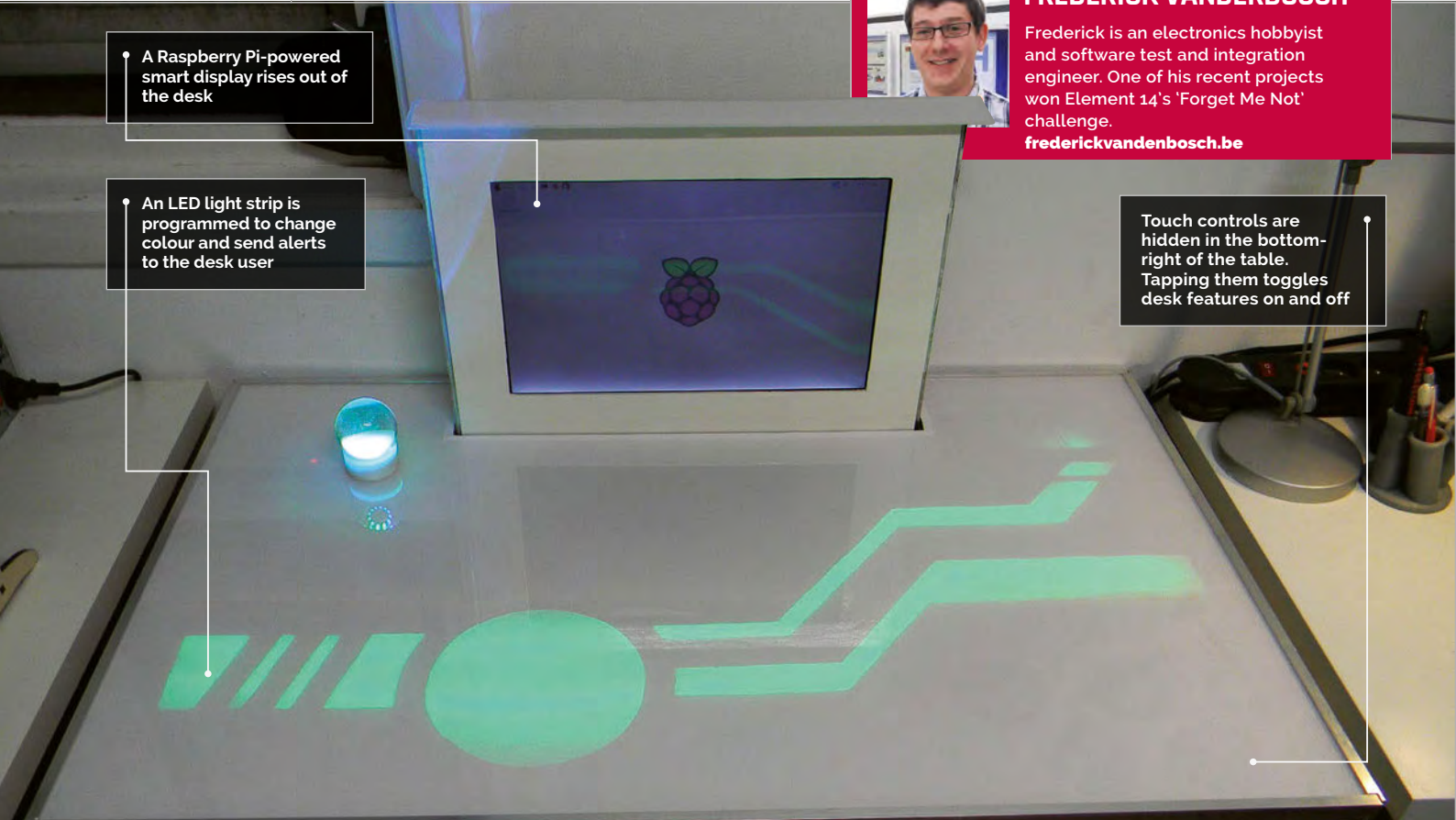

A Raspberry Pi-powered smart display rises out of the desk

An LED light strip is programmed to change colour and send alerts to the desk user

Touch controls are hidden in the bottom-right of the table. Tapping them toggles desk features on and off

**Quick Facts**

- › The entire build took about 18 weeks
- › Frederick divided the project into sub-tasks to stay motivated
- › The monitor lift is a drawer mechanism turned sideways
- › The time it takes the screen to rise matches the Pi's boot time
- › A USB sound card is used to power the built-in speakers

# PIDESK

Make any desk job exciting with this futuristic PiDesk: a touch-controlled table with lights, sound, and a computer that rises from the surface

**N**obody wants a boring desk, so one hobbyist, Frederick Vanderbosch, decided to build this futuristic workstation. Complete with a touch surface, speakers, and a motorised display that rises out of the table, the PiDesk is one of the cleverest projects we've come across.

"The build was part of a design challenge," says Frederick. The Sci-Fi Your Pi competition was launched by the Raspberry Pi Foundation and Element14 to inspire inventors to build smarter homes.

"PiDesk is an attempt at making a space-saving, futuristic-looking

desk," Frederick explains. "It can change from a regular desk to a computer workstation and back at the touch of a finger."

The idea for the project came when he was running out of space in his workplace. "By combining a computer workstation and desk in one, I would be able to get extra space to work when the computer was hidden inside the desk. For the project's futuristic accents, I was inspired by the *Tron* movies, on which I based the light patterns of the desk."

At first glance, it looks like a normal desk. As soon as the user places their hand above a

specific area, however, a desktop computer is powered on and starts rising out of the desk. This action is accompanied by visual and audio effects.

"Two Raspberry Pis are involved in the project," says Frederick. One serves as the brains of the desk; the second is a built-in desktop computer. As well as two Raspberry Pi units, the table contains a broad range of components.

The desk itself is from Ikea. "It's one of the cheaper models, which have the advantage of being hollow," reveals Frederick.

"I started by drawing some shapes on the desk to work out

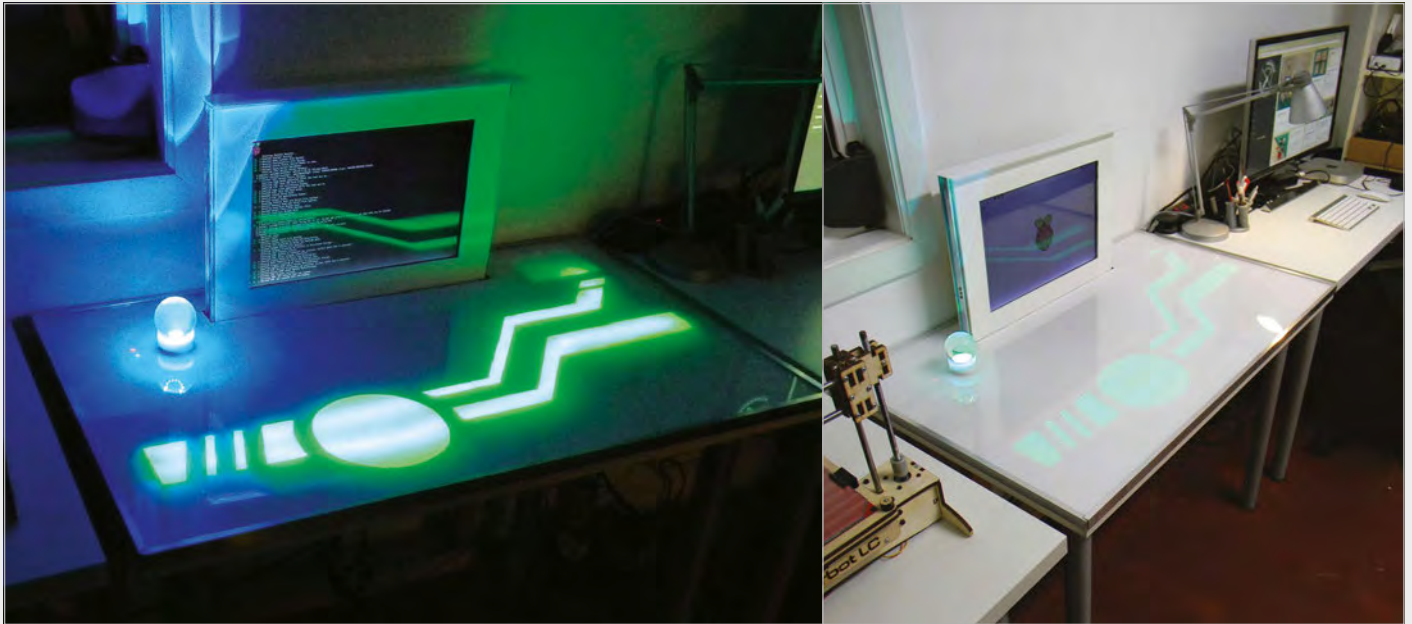

where I would perform the cuts and embed the electronics.

“Then the surface was recreated using two layers. The first layer was paper, which is used to diffuse the light and hide all the cuts and embedded electronics. The second layer is a large sheet of transparent Plexiglass, giving the desk a new and shiny surface.”

Touch controls are embedded into the surface using a combination of conductive paint

and copper tape. The paint creates touch-sensitive pads, while the tape makes a connection to the Raspberry Pi.

One neat feature you might miss is the built-in wireless charger. This is a “little bonus feature I had in mind,” says Frederick. The Magic Lamp turns on when it is placed in the right spot. “The wireless charger is embedded in the desk, and when the lamp is moved on top of it, the lamp is

powered.” The light consists of the wireless charger receiver, a microcontroller board, and a ring of Adafruit NeoPixels.

If you’re thinking of building a similar project, then planning is vital. “Plan ahead and think things through,” advises Frederick. “Break down the project into smaller, more manageable projects. There’s a lot to learn by building a project like this because so many different components are involved.”

**Above left** The built-in LED strip and Magic Lamp are especially effective in low light

**Above** The finished product is a usable desk with a display that can be lowered to provide more surface area

## BUILDING A PIDESK



### >STEP-01 Double Pi

Inside the PiDesk are two Raspberry Pis. One controls the desk interaction (lights, touch interface, and motorised display); the second acts as a built-in computer for the desk.

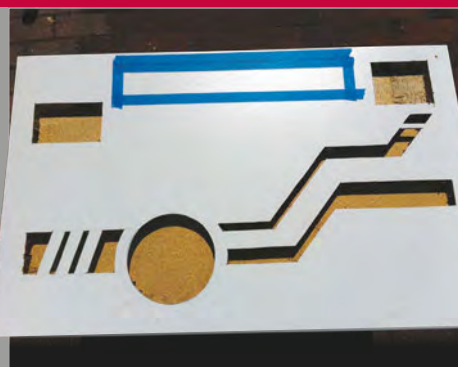

### >STEP-02 Lights and controls

The desk itself is a cheap model with a hollow centre. Holes are cut into the surface and the components are placed inside. The cuts are filled in with paper and Plexiglass to recreate a flat surface.



### >STEP-03 Desk assembly

A WS2812 LED strip is embedded into the desk to act as information lighting. Meanwhile, touch-sensitive pads are embedded to create interactive controls. A wireless charger is placed in the top-left to power the Magic Lamp.



# *The* **MagPi**

## ESSENTIALS

LEARN | CODE | MAKE

AVAILABLE NOW:

- > CONQUER THE COMMAND LINE
- > EXPERIMENT WITH SENSE HAT
- > MAKE GAMES WITH PYTHON
- > CODE MUSIC WITH SONIC PI



---

*The*  
**MagPi**  
ESSENTIALS

From the makers of the  
official Raspberry Pi magazine

---

---

**OUT NOW IN PRINT**  
**ONLY £3.99**  
*from*  
**[raspberrypi.org/magpi](http://raspberrypi.org/magpi)**

---



GET THEM  
DIGITALLY:





SIMON MONK

Simon Monk is the author of the *Raspberry Pi Cookbook* and *Programming the Raspberry Pi: Getting Started with Python*, among others. [simonmonk.org](http://simonmonk.org) / @simonmonk2 [monkmakes.com](http://monkmakes.com)

# CONTROLLING A LINEAR ACTUATOR

## You'll Need

- > 12V linear actuator (eBay)
- > RasPiRobot V3 (Amazon, Adafruit)
- > HC-SR04 ultrasonic rangefinder (eBay)
- > DC barrel socket to screw adapter (CPC: CN19646)
- > 12V DC 2A power supply
- > Two short lengths of wire

Solve real-world electronic and engineering problems with your Raspberry Pi and the help of renowned technology hacker and author, **Simon Monk**

**T**his project shows you how you can use an ultrasonic sensor as a proximity detector to trigger the extension or retraction of a powerful linear actuator, capable of opening and closing doors and windows.

As you'll see from the list of required components, this project uses a RasPiRobot Board V3 (RRB3) to control the linear actuator's motor and also provide a handy connection for the HC-SR04 rangefinder. The RRB3 also supplies your Raspberry Pi with 5V power through the GPIO connector. This should work fine if the RRB3 is connected to a good-quality power supply;

however, if you find that the Raspberry Pi resets itself when the motor starts to move, add a separate 5V USB power supply to the Raspberry Pi.

Linear actuators can be quite expensive. The cost usually depends on the travel (how far the shaft moves in and out) and the power. The one we've used here costs about £30 (\$50), has a travel of 150mm, and a pull or push force of 1500N. If you search eBay for 'linear actuator', you may well pick up a bargain.

The HC-SR04 has become the standard low-cost rangefinder, and you should be able to pick one up on eBay for a few pounds or dollars.

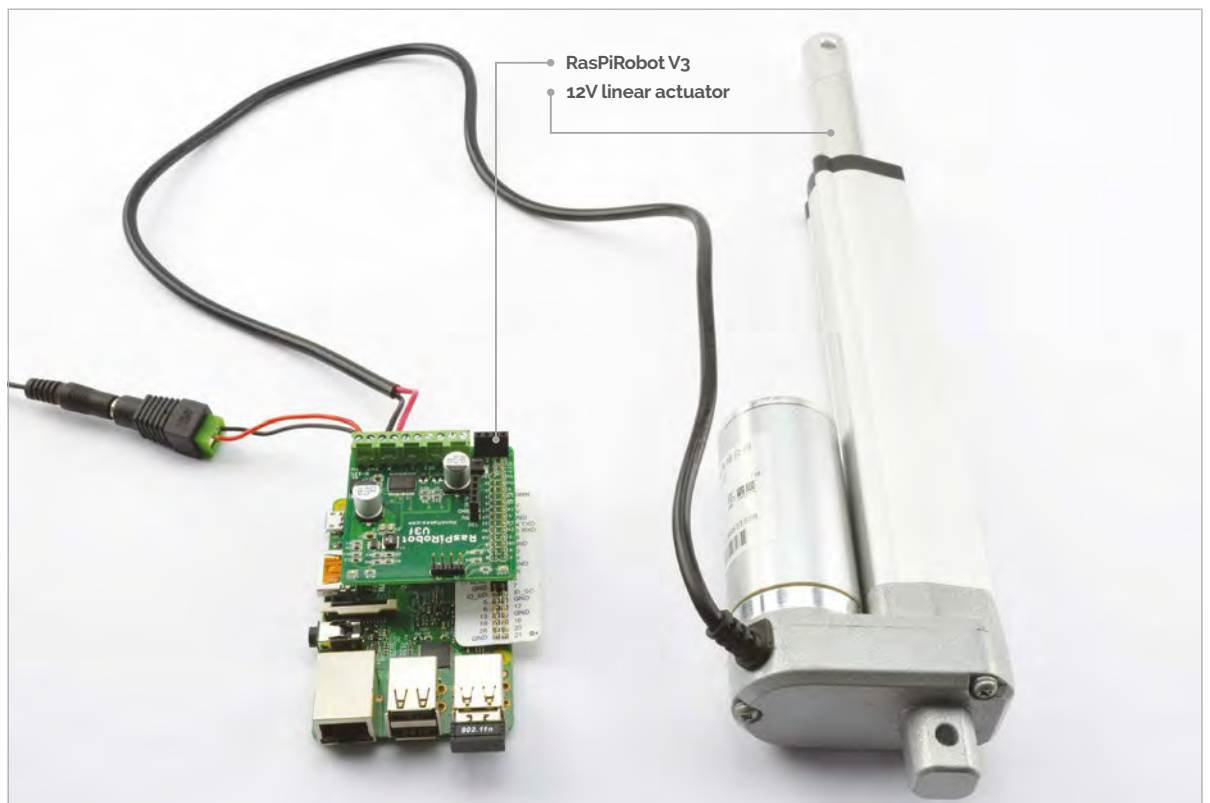

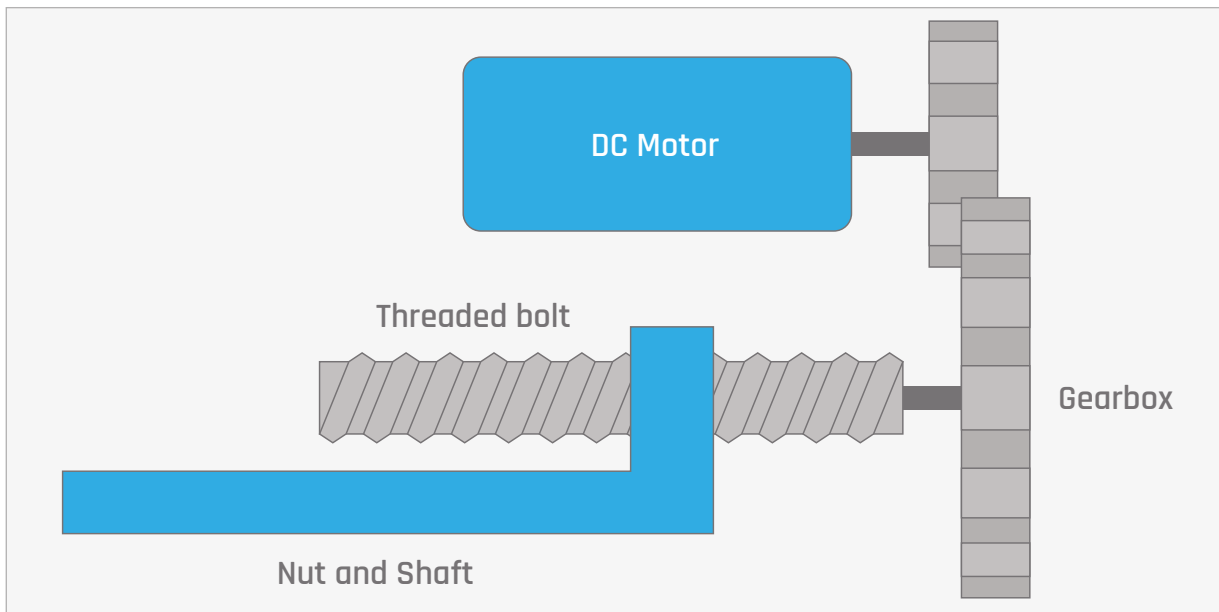

Left  
A linear actuator

## Linear actuators

Linear actuators convert the rotation of a DC motor into a linear motion. They're often used to open and close doors or windows, or to lift or lower objects. They use a threaded drive shaft with a nut on it that isn't allowed to turn, but is free to move along the threaded shaft, pushing the end of the actuator in and out.

To determine whether the linear actuator retracts or extends, you have to control the direction of current flowing through its motor. A motor controller like the RRB3 is well suited to this. The current drawn by this particular linear actuator is close to the maximum allowed for the RRB3's motor controller chip (the TB8812FNG) at 800mA. However, the chip can cope with greater currents for a short time and has its own

protection circuitry that will prevent it overheating.

You don't have to worry about the linear actuator damaging itself if you keep supplying power to it when it has reached the end of its travel, because most contain an auto-shutoff feature that removes the power once the shaft is fully out or fully in.

## eBay alternative

If you have a linear actuator that takes more current than this one, or just want a lower-cost alternative to the RRB3, then search for 'L298' on eBay and you should find a module like the one shown here for a few pounds or dollars. You will also need two female-to-female jumper wires and one female-to-male jumper wire. Use the female-to-female wires to connect the control pins IN3 and IN4 on the module to GPIO pins

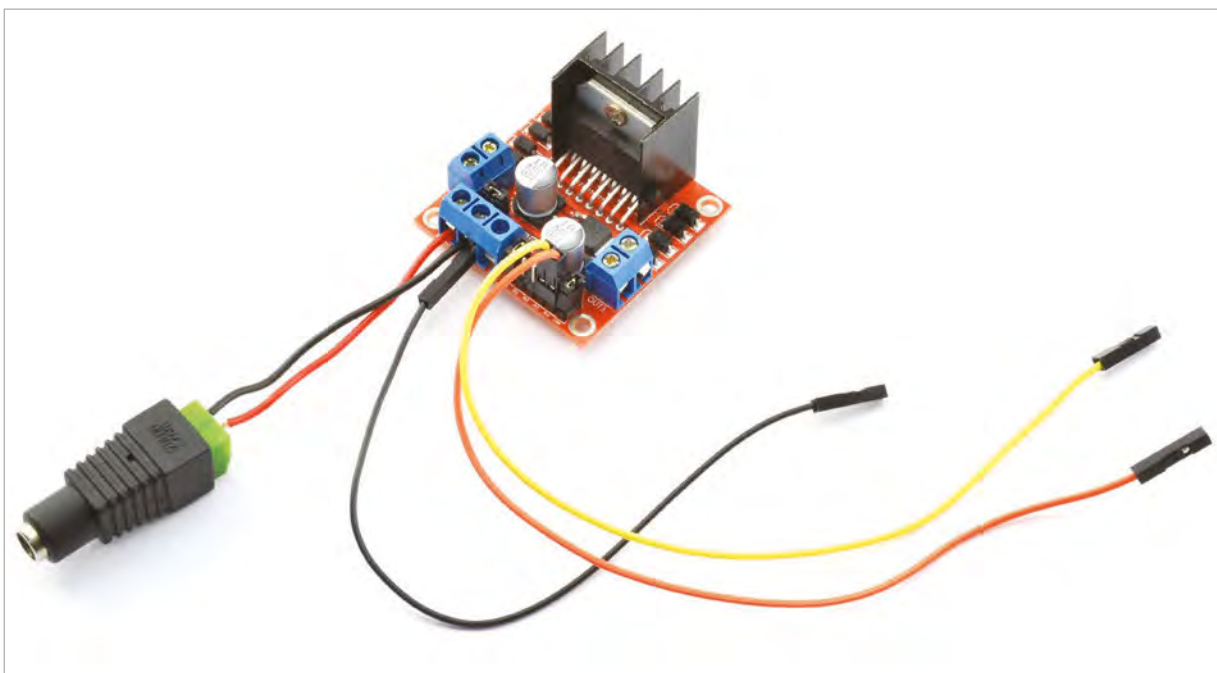

Left A low-cost  
L298 motor  
controller

## BUILDING THE PROJECT

This is a very straightforward project to build. It's just a case of attaching wires to screw terminals and plugging things together.

### >STEP-01

#### Fit the RRB3 onto your Raspberry Pi

The RRB3 is designed to work with older Raspberry Pis with 26 pin headers, but will work just fine with 40-pin Raspberry Pis like the Pi 2, Zero, A+, and B+. Just make sure that you fit the RRB3 onto the end of the row of GPIO header pins on a 40-pin Pi.

### >STEP-02

#### Attach the socket adapter

You'll need to use a couple of short lengths of wire to link the screw terminal adapter to the RRB3. It's a good idea to use red and black wires, to make sure the red goes to the positive (+) terminal on both the RRB3 and the terminal adapter, and the black connects the negative terminals.

10 and 25 respectively on the Raspberry Pi. These are the same GPIO pins that the RRB3 library uses, so you won't need to change the code.

The female-to-male jumper wire has its male end in the motor controller GND screw terminal, sharing the GND screw terminal with the negative lead to the power supply. The other end of the male-to-female wire goes to GND on the GPIO connector. The +12V wire from the power supply goes to the screw terminal marked +12V.

Connect the leads from the linear actuator to the screw terminals on the motor controller board marked OUT3 and OUT4.

## Building your project

As always, it's a good idea to test the project out and get everything working while the parts are all out on your workspace. Once you know all is well, you can box up the project and fix your linear actuator in place, ready to open, close or lift whatever you have in mind for it. Now that the hardware side of the project is complete, we just need to get the software running. The program is written in Python and uses a library that accompanies the RRB3. To install this, enter:

```
sudo pip install rrb3
```

You can also download the program for this project from the command line using:

```
git clone https://github.com/simonmonk/pi_magazine.git
```

To run the program, change directory to the one where the code for this project lives and then run the program using the commands below:

```
cd /home/pi/pi_magazine/13_linear_actuator
sudo python lin_act.py
```

If you now move your hand in front of the rangefinder, LED1 on the RRB3 should turn on and the linear actuator should start to extend. Once the linear actuator is fully extended, it will stop. When LED1 goes out, waving your hand in front of the rangefinder will start the actuator retracting.

## How the code works

The Python code for this program is well commented. You'll probably find it handy to have the code up in an editor while we go through it.

The program starts by importing the **rrb3** library that it needs. The constant **T** is set to slightly longer than the time taken in seconds for the motor to extend or retract fully, whichever takes longer. This is how long the motor will be asked to run for when retracting or extending. Remember that the motor will automatically cut out at each end of its travel.

The **extended** variable is used to keep track of whether the linear actuator is extended or not. The main **while** loop waits for the rangefinder to detect something closer than 20cm from it and then either sets the motor to run forward or in reverse, depending on the value of **extended**. For good measure, one of the LEDs on the RRB3 is lit while the motor is being powered, and a message is printed out.

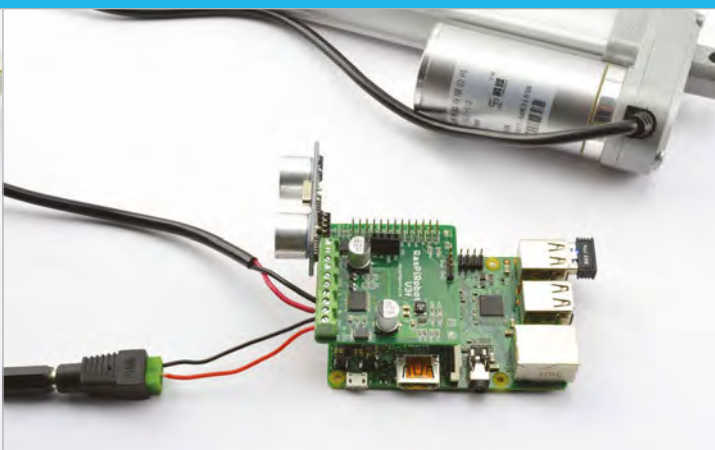
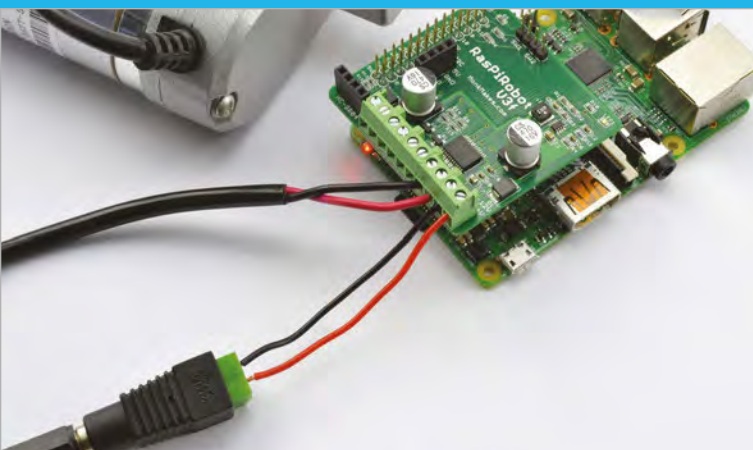

**>STEP-03****Connect the linear actuator**

Connect the two leads from the linear actuator to the pair of terminals marked 'R' on the RRB3. The red lead from the linear actuator should go to the terminal nearest the two power terminals.

If, when you test the project, the motor moves in the opposite direction to what you were expecting, swap over these two wires.

**>STEP-04****Fit the rangefinder**

Finally, attach the rangefinder to the RRB3 in the socket labelled 'HC-SR04'. At this point, you can also attach the power supply to the adapter socket and, if you wish, disconnect USB power from the Raspberry Pi, although it won't do any harm if you don't disconnect the USB power.

The whole **while** loop is contained in a **try / finally** clause so that when the program is quit using **CTRL+C**, the GPIO pins are set back to be inputs.

**Using your linear actuator**

Linear actuators like the one used here are actually very strong. If you have any doubt as to the power of one of these devices, take a look at this video – [youtu.be/qbWMEIFnq2I](https://youtu.be/qbWMEIFnq2I) – which shows a can-crusher using this linear actuator, built by your expert for his book *Make: Action: Movement, Light, and Sound with Arduino and Raspberry Pi*.

If it will crush cans, however, it will crush fingers, so be careful!

A common use of linear actuators is to automatically open a skylight window when the temperature exceeds a certain point. You could use a temperature sensor with this project, such as the DC18B20, and even add a web interface to control things from your browser.

**THE END**

This article is the last in my Everyday Engineering series. I hope you have enjoyed all 13 projects in the series as much as I have devising them. If you like my writing, then you'll probably enjoy my books, especially *Programming Raspberry Pi*, *The Raspberry Pi Cookbook*, and *The Maker's Guide to the Zombie Apocalypse*.

Finally, this is not goodbye as *The MagPi* will be serialising excerpts from my book *Programming Raspberry Pi: Getting Started in Python* over the next few months. You can also follow me on Twitter via [@simonmonkz](https://twitter.com/simonmonkz).

**lin\_act.py**

```
from rrb3 import *
from random import randint

rr = RRB3(12, 12) # Battery voltage 12V, motor 12V

T = 20 # 20 seconds to extend

extended = False

try:
    while True:
        if rr.get_distance() < 20:
            if extended: # if extended retract and vice versa
                print("retracting")
                rr.set_led1(True) # LED 1 on
                rr.reverse(T, 1.0)
                rr.set_led1(False)
                extended = False
            else:
                print("extending")
                rr.set_led2(True)
                rr.forward(T, 1.0)
                rr.set_led2(False)
                extended = True
            print("done")
finally:
    rr.cleanup() # Set all GPIO pins to safe input state
```

Language

&gt;PYTHON

DOWNLOAD:

[magpi.cc/1PK4jds](https://magpi.cc/1PK4jds)



**WESLEY ARCHER  
(AKA RASPBERRY COULIS)**

Self-taught Raspberry Pi enthusiast, now writing guides for Pi Supply's Maker Zone to help others get involved in gadgety goodness!  
[Raspberrycoulis.wordpress.com](http://Raspberrycoulis.wordpress.com)  
[Facebook.com/raspberrycoulis](https://Facebook.com/raspberrycoulis)  
[@Raspberrycoulis](https://Twitter.com/Raspberrycoulis)

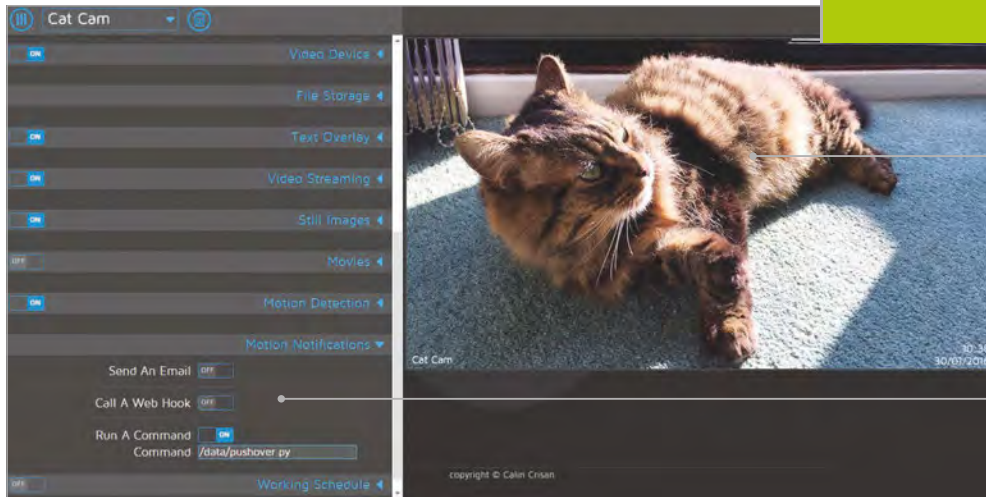

Busted! This is what your camera sees (and records) when motion is detected

This is where you'll tell MotionEyeOS to run your Python script

**You'll Need**

- > MotionEyeOS [magpi.cc/1UCw1Jk](http://magpi.cc/1UCw1Jk)
- > Raspberry Pi Camera Module
- > Pushover app for iOS or Android with full licence (£3.99/\$4.99) [pushover.net](http://pushover.net)

# ADD PUSH NOTIFICATIONS TO MOTIONEYEOS

MotionEyeOS is perfect for using your Pi as a CCTV camera. Want to detect movements while you're out? Then read on...

**O**ne benefit of MotionEyeOS is its ability to detect motion and capture images and movies of what triggered it. You can also access a live stream of your camera online, even when you're not home, which is handy if you want to check in every now and then. When away from home, being notified of any movement is very useful, and MotionEyeOS has a nifty option for custom notifications.

This guide will assume you have already set up and configured MotionEyeOS. A Pushover licence is required, which costs £3.99/\$4.99. For help, check out the MotionEyeOS wiki here: [magpi.cc/1UCvYwV](http://magpi.cc/1UCvYwV).

**Right** Make sure you turn on 'Run A Command' and then include the path to your script!

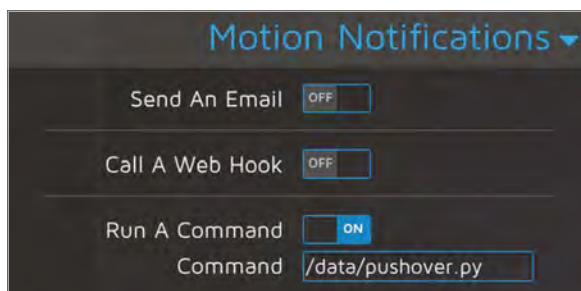

## >STEP-01

### Create an application in Pushover

Pushover has a great, easy to use API. Before we start, we need to register an application with it. Click on Register Application under the Your Applications heading on the Pushover website ([pushover.net](http://pushover.net)). Give your app a name – something like RaspMotion – and then make sure the type is Application. Give your app a quick description (e.g. 'Push notifications sent by my Raspberry Pi') and, if feeling creative, upload a custom icon which will show in your Pushover client app whenever a notification is sent.

## >STEP-02

### Get your API token and user key

Once you have created your application, you should have access to an API token/key. This is a unique combination of numbers and letters – please keep this a secret! You'll also need your user key, which is shown once you log into Pushover's website. Okay, so you have an app and your API and user keys. You'll now need to download (or recreate if you so

Language

>PYTHON

DOWNLOAD:  
magpi.cc/  
zoDHpYW

# pushover.py

```
import http, urllib

conn = http.HTTPSConnection("api.pushover.net:443")
conn.request("POST", "/1/messages.json",
    urllib.urlencode({
        "token": "APP_TOKEN",
        "user": "USER_TOKEN",
        "html": "1",
        "title": "Motion Detected!",
        "message": "<b>Front Door</b> camera!",
        "url": "http://IP.ADD.RE.SS",
        "url_title": "View live stream",
        "sound": "siren",
    }), { "Content-type": "application/x-www-form-urlencoded" })
conn.getresponse()
```

# Insert app token here  
# Insert user token here  
# 1 for HTML, 0 to disable  
# Title of the message  
# Content of the message  
# Link to be included in message  
# Text for the link  
# Define the sound played

wish) a simple Python script to tell your Raspberry Pi to work its magic once the script is called upon by MotionEyeOS.

## >STEP-03 Create your Python script

MotionEyeOS is not like Raspbian. You cannot use certain commands as you would normally, such as **git clone**, so we'll have to create our Python script manually; you can also drag and drop using WinSCP if preferred. We also don't need to use **sudo**, as we're already logged in as root by default. Our script needs to live in the **data** folder, so let's go there and create **pushover.py** using nano:

```
cd /data
nano pushover.py
```

Once here, you'll need to copy and paste or type in the code listing, while also including your API token and user key where required.

## >STEP-04 Make your script executable

As with any script, we need to make sure it can be executed, otherwise it's nothing more than a fancy collection of text! You can do this either from the command line or from within WinSCP. From the command line, make sure you're in the **data** folder and then type:

```
chmod +x pushover.py
```

Or, if using WinSCP, select the **pushover.py** file in the **data** folder, then press **F9**. In the window that appears, change the permissions to **0755** and then click 'OK' to confirm.

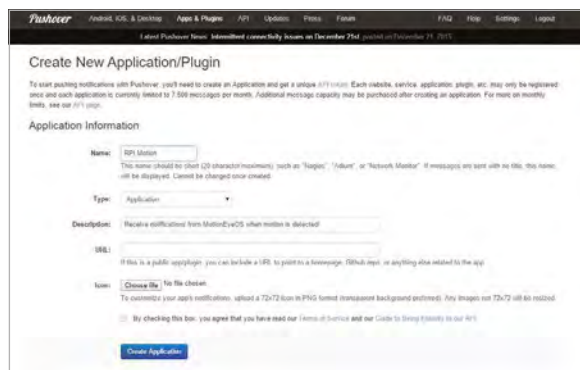

Left Create an app via Pushover.net to get the ball rolling. It's pretty self-explanatory

## >STEP-05 Configure MotionEyeOS to use your script

Now that we have our script, we need to tell MotionEyeOS to use it when it detects motion. To do this, log in, go to the Motion Notifications menu and turn on the 'Run A Command' option. You then need to specify which command to run, which will be the Python script you just created – this is **/data/pushover.py**. Click Apply once done, to confirm the changes.

## >STEP-06 Test it out!

Hopefully, by now you have created your Python script, made it executable, told MotionEyeOS to use your script when it detects motion, and have the Pushover app installed on your smartphone or tablet. We now need to test that it works! Wave your hand in front of your camera (or you can do a dance if you're feeling energetic!) and then shortly afterwards you should receive a notification via Pushover, warning you that motion has been detected!

Feel free to experiment with the script to customise the message displayed and sound played in Pushover.



# π))) Sonic Pi PART 8

# CONTROLLING YOUR SOUND

## You'll Need

- > Raspberry Pi running Raspbian
- > Sonic Pi v2.7+
- > Speakers or headphones with a 3.5mm jack
- > Update Sonic Pi: `sudo apt-get update && sudo apt-get install sonic-pi`

In this month's Sonic Pi guide, creator **Sam Aaron** shows you how to shape and sculpt your sounds...

**S**o far during this series, we've focused on triggering sounds. We've discovered that we can trigger the many synths built into Sonic Pi with **play** or **synth**, and how to trigger pre-recorded samples with **sample**. We've also looked at how we can wrap these triggered sounds within studio FX such as reverb and distortion, using the **with\_fx** command. Combine this with Sonic Pi's incredibly accurate timing system and you can produce a vast array of sounds, beats, and riffs. However, once you've carefully selected a particular sound's options and triggered it, there's no ability to mess with it whilst it's playing, right? Wrong! Today you're going to learn something very powerful: how to control running synths.

## A basic sound

Let's create a nice simple sound. Fire up Sonic Pi and, in a fresh buffer, type the following:

```
synth :prophet, note: :e1, release: 8,
  cutoff: 100
```

Now press the Run button at the top left to hear a lovely rumbling synth sound. Go ahead, press it again a few times to get a feel for it. OK, done? Let's start controlling it!

## Synth nodes

A little-known feature in Sonic Pi is that the fns **play**, **synth**, and **sample** return something called a **SynthNode**, which represents a running sound. You can capture one of these **SynthNodes** using a standard variable and then **control** it at a later point in time. For example, let's change the value of the **cutoff**: opt after one beat:

```
sn = synth :prophet, note: :e1, release: 8,
  cutoff: 100
sleep 1
control sn, cutoff: 130
```

Let's look at each line in turn...

Firstly, we trigger the **:prophet** synth using the **synth** fn, as normal. However, we also capture the result in a variable called **sn**. We could have called this variable something completely different, such as 'synth\_node' or 'jane' – the name doesn't matter. However, it's important to choose a name that's meaningful to you for your performances and for people reading your code. We chose **sn** as it's a nice short mnemonic for synth node.

On line 2 we have a standard **sleep** command. This does nothing special – it just asks the computer to wait for one beat before moving onto the next line.

Line 3 is where the control fun starts. Here, we use the **control** fn to tell our running **SynthNode** to change the cutoff value to **130**. If you hit the Run button, you'll hear the **:prophet** synth start playing as before, but after one beat it will shift to sound a lot brighter.

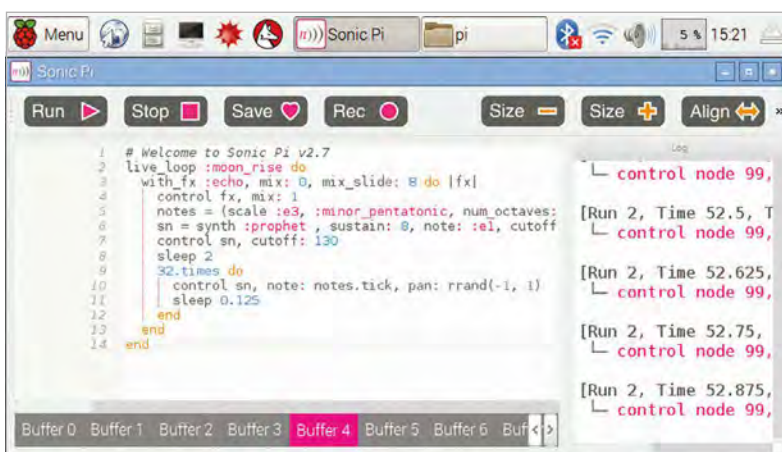

## Multiple changes

Whilst a synth is running, you're not limited to changing it only once – you're free to change it as many times as you like. For example, we can turn our `:prophet` into a mini arpeggiator with the following:

```
notes = (scale :e3, :minor_pentatonic)
sn = synth :prophet, note: :e1, release: 8,
  cutoff: 100
sleep 1
16.times do
  control sn, note: notes.tick
  sleep 0.125
end
```

In this snippet of code, we just added a couple of extra things. Firstly, we defined a new variable called `notes`, which contains the notes we'd like to cycle through (an arpeggiator is just a fancy name for something that cycles through a list of notes in order). Secondly, we replaced our single call to `control` with an iteration calling it 16 times. In each call to `control`, we `.tick` through our ring of `notes`, which will automatically repeat once we get to the end (thanks to the fabulous power of Sonic Pi's rings). For a bit of variety, try replacing `.tick` with `.choose` and see if you can hear the difference.

Note that we can change multiple opts simultaneously. Try changing the control line to the following and listen for the difference:

```
control sn, note: notes.tick,
  cutoff: rrand(70, 130)
```

## Sliding

When we control a `SynthNode`, it responds exactly on time and instantly changes the value of the opt to the new one, as if you'd pressed a button requesting the change. This can sound rhythmical and percussive – especially if the opt controls an aspect of the timbre, such as `cutoff:`. However, sometimes you don't want the change to happen instantaneously. Instead, you might want to smoothly move from the current value to the new one, as if you'd moved a slider or dial. Of course, Sonic Pi can also do this too using `_slide:` opts.

Each opt that can be modified also has a special corresponding `_slide:` opt that allows you to specify a slide time. For example, `amp:` has `amp_slide:`, and `cutoff:` has `cutoff_slide:`. These slide opts work slightly differently from all the other opts in that they tell the synth nodes how to behave *next time they are controlled*. Let's take a look:

```
sn = synth :prophet, note: :e1, release: 8,
  cutoff: 70, cutoff_slide: 2
sleep 1
control sn, cutoff: 130
```

## Modulatable options

Language

&gt; RUBY

Most of Sonic Pi's synths and FX opts may be changed after being triggered. However, this isn't the case for all of them. For example, the envelope opts `attack:`, `decay:`, `sustain:`, and `release:` can only be set when triggering the synth. Figuring out which opts can and can't be changed is simple – just head to the documentation for a given synth or FX, then scroll down to the individual option documentation and look for the phrases 'May be changed whilst playing' or 'Can not be changed once set'. For example, the documentation for the `:beep` synth's `attack:` opt makes it clear that it's not possible to change it:

- › Default: 0
- › Must be zero or greater
- › Can not be changed once set
- › Scaled with current BPM value

Note how this example is the same as before, except with the addition of `cutoff_slide:`. This is saying that next time this synth has its `cutoff:` opt controlled, it will take two beats to slide from the current value to the new one. Therefore, when we use `control`, you can hear the cutoff slide from 70 to 130. It creates an interesting dynamic feel to the sound. Now, try reducing the `cutoff_slide:` time to 0.5, or increasing it to 4, to see how it changes the sound. Remember, you can slide any of the modifiable opts in this way, and each `_slide:` value can be totally different, so you can have the cutoff sliding slowly, the amp sliding fast, and the pan sliding somewhere in between if you like.

## Bringing it all together

Let's look at a short example which demonstrates the power of controlling synths after they've been triggered. Note that you can also slide FX just like synths, but with a slightly different syntax. Check out section 7.2 of the built-in tutorial for more information on controlling FX.

Copy the code into a spare buffer and listen. Don't stop there, though – play around with the code. Change the slide times, the notes, the synth, the FX, and the sleep times and see if you can turn it into something completely different!

```
live_loop :moon_rise do
  with_fx :echo, mix: 0, mix_slide: 8 do |fx|
    control fx, mix: 1
    notes = (scale :e3, :minor_pentatonic,
      num_octaves: 2).shuffle
    sn = synth :prophet, sustain: 8, note: :e1, cutoff: 70,
      cutoff_slide: 8
    control sn, cutoff: 130
    sleep 2
    32.times do
      control sn, note: notes.tick, pan: rrand(-1, 1)
      sleep 0.125
    end
  end
end
```



**SEAN MCMANUS**

Sean McManus is the author of *Raspberry Pi For Dummies* (with Mike Cook), and *Scratch Programming in Easy Steps*.  
[sean.co.uk](http://sean.co.uk)  
[twitter.com/musicandwords](https://twitter.com/musicandwords)



Notes go green when you play them, and you hear a recording from Sonic Pi

Get a note wrong and you hear a thud, and the note goes red. Keep trying!

As you progress, more sharps and flats are introduced to the game

# CLEF HERO: CREATE A MUSIC GAME USING THE PIANO HAT

**You'll Need**

- > Piano HAT [magpi.cc/1OALwNT](http://magpi.cc/1OALwNT)
- > Some speakers on your Pi
- > Pygame Zero [magpi.cc/1XdhRji](http://magpi.cc/1XdhRji)

Put a piano on your Pi, and learn to tinkle the ivories. This game teaches you to read music and program the Piano HAT.

**P**imoroni's Piano HAT provides a musical keyboard for your Pi, with LEDs for illuminating the keys. In Clef Hero, you're challenged to play a pattern of notes shown on the staff. It starts easy, but gets harder as more notes, sharps, and flats are introduced. As you move up the staff you'll reuse keys for the higher octave so, for example, the 'D' key is the right answer for either D on the staff. Standard sheet music wouldn't normally include the mishmash of sharps and flats you can get on the higher levels, but that makes Clef Hero a challenging puzzle even for those with some experience.

**>STEP-01  
 Make some sounds**

First, we'll make a single audio file that contains all the notes we'll need. The Listing 1 code for Sonic Pi (on page 54) will play the notes in order. Enter the listing in one of the Sonic Pi buffer spaces. Press the Rec button to start recording, press Run to play the notes, and then press Rec again to save your recording. You

can customise the sounds and use different synths, but don't make the sounds too long or the game will become unplayable.

**>STEP-02  
 Split the note files**

To split your sound recording into individual files for each note, use Audacity. Install it by entering the command `sudo apt-get update && sudo apt-get install audacity` in a terminal. Open your audio file - the default option to make a copy to edit is fine, if you're asked. From the Analyze menu, choose Silence Finder. Set the minimum duration to 0.10 and the label placement to 0.05, then click OK. Go to the Edit menu and click Preferences. In the Import/Export options, untick 'Show Metadata Editor'. From the File menu, choose Export Multiple. Use the WAV export format, choose 'Numbering after File name prefix', and enter the File name prefix of 'note'. Create a directory called **clef**, and a directory called **sounds** inside that. Choose the **sounds** directory as your export location and click Export.

## clef.py

```
# Clef Hero by Sean McManus
import pianohat, random, time
WIDTH, HEIGHT = 600, 440
RED = (255,0,0)
GREEN = (0,255,0)
BLUE = (0,0,255)
notes_to_play = list()
note_colours = list()
level = 1
notes_data = [
[0, sounds.note_01, 1, ""], [2, sounds.note_03, 2, ""],
[4, sounds.note_05, 3, ""], [5, sounds.note_06, 4, ""],
[7, sounds.note_08, 5, ""], [9, sounds.note_10, 6, ""],
[11, sounds.note_12, 7, ""], [0, sounds.note_13, 8, ""],
[2, sounds.note_15, 9, ""], [4, sounds.note_17, 10, ""],
[5, sounds.note_18, 11, ""], [7, sounds.note_20, 12, ""],
[9, sounds.note_22, 13, ""],
[1, sounds.note_02, 1, "#"], [3, sounds.note_04, 2, "#"],
[6, sounds.note_07, 4, "#"], [8, sounds.note_09, 5, "#"],
[10, sounds.note_11, 6, "#"], [1, sounds.note_14, 8, "#"],
[3, sounds.note_16, 9, "#"], [6, sounds.note_19, 11, "#"],
[8, sounds.note_21, 12, "#"], [10, sounds.note_23, 13, "#"],
[1, sounds.note_02, 2, "b"], [3, sounds.note_04, 3, "b"],
[6, sounds.note_07, 5, "b"], [8, sounds.note_09, 6, "b"],
[10, sounds.note_11, 7, "b"], [1, sounds.note_14, 9, "b"],
[3, sounds.note_16, 10, "b"], [6, sounds.note_19, 12, "b"],
[8, sounds.note_21, 13, "b"]
]

def round_setup():
    global note_position, note_number, notes_to_play
    del notes_to_play[:]
```

```
del note_colours[:]
level_data = notes_data[0 : level * 4]
for i in range(8):
    notes_to_play.append(random.choice(level_data))
    note_colours.append(BLUE)
note_position = 0
note_number = 0
clock.schedule_unique(hint_on, 5)

def draw():
    screen.blit(images.clef_background, (0,0))
    screen.draw.text("Clef", (310,90), color="blue", fontsize=120)
    screen.draw.text("Clef", (315,85), color="white", fontsize=120)
    screen.draw.text("Hero", (310,180), color="blue", fontsize=120)
    screen.draw.text("Hero", (315,175), color="white", fontsize=120)
    BOX = Rect((100,290), (400,120))
    SHADOW = Rect((105,295), (400,120))
    screen.draw.filled_rect(SHADOW, (0,0,0))
    screen.draw.filled_rect(BOX, (255,255,255))
    screen.blit(images.treble_clef,(105,305))
    for y in range(5):
        screen.draw.line((110, 380 - y*16), (490, 380 - y*16), (0,0,0))
    show_notes()

def show_notes():
    for i in range(8):
        draw_note(i)

def draw_note(note_number):
    screen.draw.filled_circle((180 + note_number * 35, 404 - notes_to_play[
note_number][2]*8), 7, note_colours[note_number])
    if notes_to_play[note_number][2] == 1 or notes_to_play[note_number][2] == 13:
        screen.draw.line((170 + note_number * 35, 404 - notes_to_play[
note_number][2]*8), (190 + note_number * 35, 404 - notes_to_play[note_number]
```

Language  
>PYTHON

## &gt;STEP-03

## Fix your hyphens

Audacity exports your files with names like note-01.wav, note-02.wav, and so on, but Pygame Zero requires underscores, not hyphens. To do the bulk rename, we recommend you install `mmv` with `sudo apt-get install mmv`. Then `cd` to the `sounds` directory where you have the files Audacity exported, and enter the command `mmv "note-*.wav" "note_#1.wav"`. Copy `thud.wav` into `sounds` too, from `pi/Pimoroni/pianohat/sounds/drums`. It's used when the player presses the wrong key.

## &gt;STEP-04

## Prepare your art

You'll need a treble clef and a background image. We're using a treble clef from [magpi.cc/1XdhNA3](http://magpi.cc/1XdhNA3) (download the small version) and a background by Gerd Altmann ([magpi.cc/1XdhOnK](http://magpi.cc/1XdhOnK)) – again, use the small one. Rename your clef to `treble_clef.png` and your background to `clef_background.jpg`.

Below Use Audacity to split your Sonic Pi recording into notes

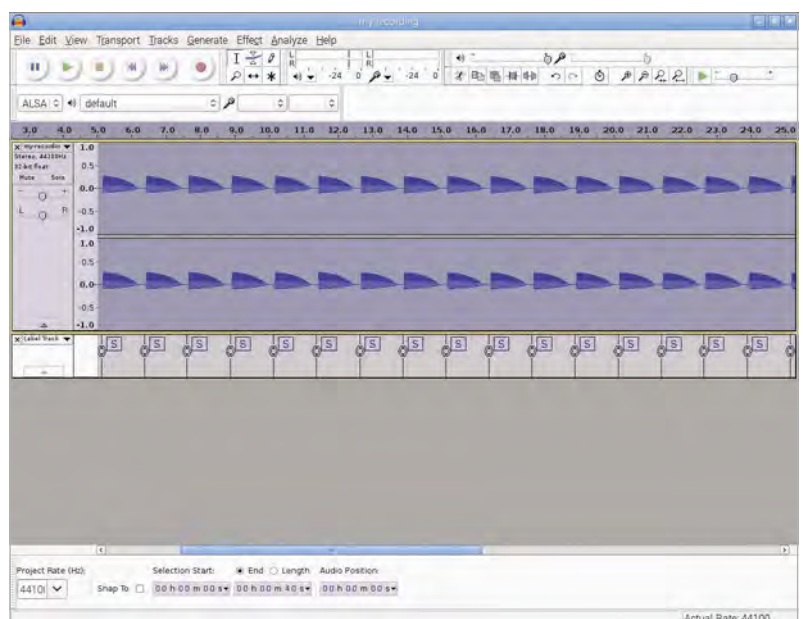



```
[2]*8), note_colours[note_number])
    screen.draw.text(notes_to_play[note_number][3], (
162 + note_number * 35, 395 - notes_to_play[note_number][2]*8),
color = note_colours[note_number], fontsize=24)

def update():
    draw_note(note_position)

def handle_note(piano_key, pressed):
    global note_position, note_colours, level
    if pressed == False: # key was released, not pressed
        return
    if piano_key == 12: # if top C pressed
        piano_key = 0 # treat it the same as bottom C
    clock.unschedule(hint_on)
    if piano_key == notes_to_play[note_position][0]:
        note_colours[note_position] = GREEN
        notes_to_play[note_position][1].play()
        lights_out()
        if note_position < 7:
            note_position += 1
        else:
            lights_on()
            if level < 8:
                level += 1
                round_setup()
            clock.schedule_unique(hint_on, 5)
    else:
        note_colours[note_position] = RED
```

Language  
 >SONIC PI

### Listing 1

```
note = 60
with_synth :tb303 do
    22.times do
        play note
        note = note + 1
        sleep 1.25
    end
end

sounds.thud.play()

def hint_on():
    pianohat.set_led(notes_to_play[note_position][0], True)

def lights_out():
    for light in range(16):
        pianohat.set_led(light, False)

def lights_on():
    for light in range(13):
        pianohat.set_led(light, True)
    clock.schedule_unique(lights_out, 1)

lights_on()
round_setup()
pianohat.auto_leds(False)
pianohat.on_note(handle_note)
```

Resize your clef to 62x110 pixels. You can use **sudo apt-get install imagemagick** and then **convert treble\_clef.png -resize 62x100 treble\_clef.png** to resize the image from the command line. Create a directory called **images** inside the **clef** directory and put your pictures there. This is where Pygame Zero looks for all its images.

**Below** Use Sonic Pi to make (and customise) the sounds for this game



### >STEP-05

#### Build the Clef Hero game

The main code listing shown contains the Python code for the Clef Hero game. Call it **clef.py** and put it into your **clef** directory, so it sits immediately above the **sounds** and **images** directories, as Pygame Zero will expect. You run it with **sudo pgzrun clef.py** from LXTerminal in the desktop environment. Each level has eight notes. When you play a note correctly, it goes green. When you complete the level, another eight notes are chosen randomly. The range of notes starts small, but increases with each screen you finish until all notes are in play. Tap the black notes carefully: it's easy to also hit a white key by mistake.

### >STEP-06

#### It's time for your solo!

There's lots you can do to customise Clef Hero. The list **notes\_data** describes the notes - the data is Piano HAT key, sound file, the staff line or space numbered from C=1 at the bottom, and the sharp or flat symbol. To have notes arrive in a different order, change their place in this list. To play with all the notes from the start, add **random.shuffle(notes\_data)** immediately after **notes\_data** is defined. Why not add a score or a time limit? Or adapt the game for the bass clef? Jam with it!



# MONK MAKES

Books & Other Bright Ideas from Simon Monk



## Electronics Starter Kit for Raspberry Pi

This kit contains everything you need (apart from a Raspberry Pi) to create ten electronic projects.

£15 / \$25

- 10 easy to follow project cards
- Quality 400 tie-point breadboard
- 20 jumper wires
- All Python code in one easy download
- Compatible with Pi B, B+, A+, Pi 2
- Includes RGB LED, red LEDs, switches, buzzer, light sensor, temperature sensor, and capacitor
- No soldering required



## RasPiRobot Board v3

A simple to use motor controller for the Raspberry Pi. This board is designed to simplify the process of making small roving robots and controlling medium power loads using a Raspberry Pi.

£17.50 / \$25 - \$29.95

- Dual bi-directional motor control using TB6612FNG dual H-bridge
- Dual open drain 2A MOSFET outputs
- Socket for HC-SR04 Rangefinder
- Socket for 5V I2C Interface
- Provides regulated power to Raspberry Pi
- 2 x user controllable LEDs
- 2 x header pins for switches
- Reverse polarity protection
- Open Source Python Software library
- Screw terminals for motor and power connections
- Compatible with Pi, B+, A+, Pi2

**Please note:** Illustration of possible use only, chassis, Raspberry Pi, motors, rangefinder etc. not included



## Raspberry Squid Combo Pack

Using the included Raspberry Leaf GPIO template, attach an RGB LED and push buttons directly to the GPIO pins of a Raspberry Pi. The switches are panel-mountable and perfect when putting your Raspberry Pi project into an enclosure.

£9.65 / \$14.95

- Includes one RGB LED Squid and two Squid Buttons and a Raspberry Leaf GPIO template
- RGB LED and switches plug directly into Raspberry Pi GPIO pins
- Simple to use Python library for RGB LED control and switch debouncing

GET A 10%  
DISCOUNT

when you buy through  
**amazon.com** or **amazon.co.uk**

Enter promo code: **MAGPINOW**

[www.monkmakes.com](http://www.monkmakes.com) | [twitter@monkmakes](https://twitter.com/monkmakes)

# MIKE'S PI BAKERY



**MIKE COOK**

Veteran magazine author from the old days and writer of the Body Build series. Co-author of *Raspberry Pi for Dummies*, *Raspberry Pi Projects*, and *Raspberry Pi Projects for Dummies*. [magpi.cc/1NqldHU](http://magpi.cc/1NqldHU)

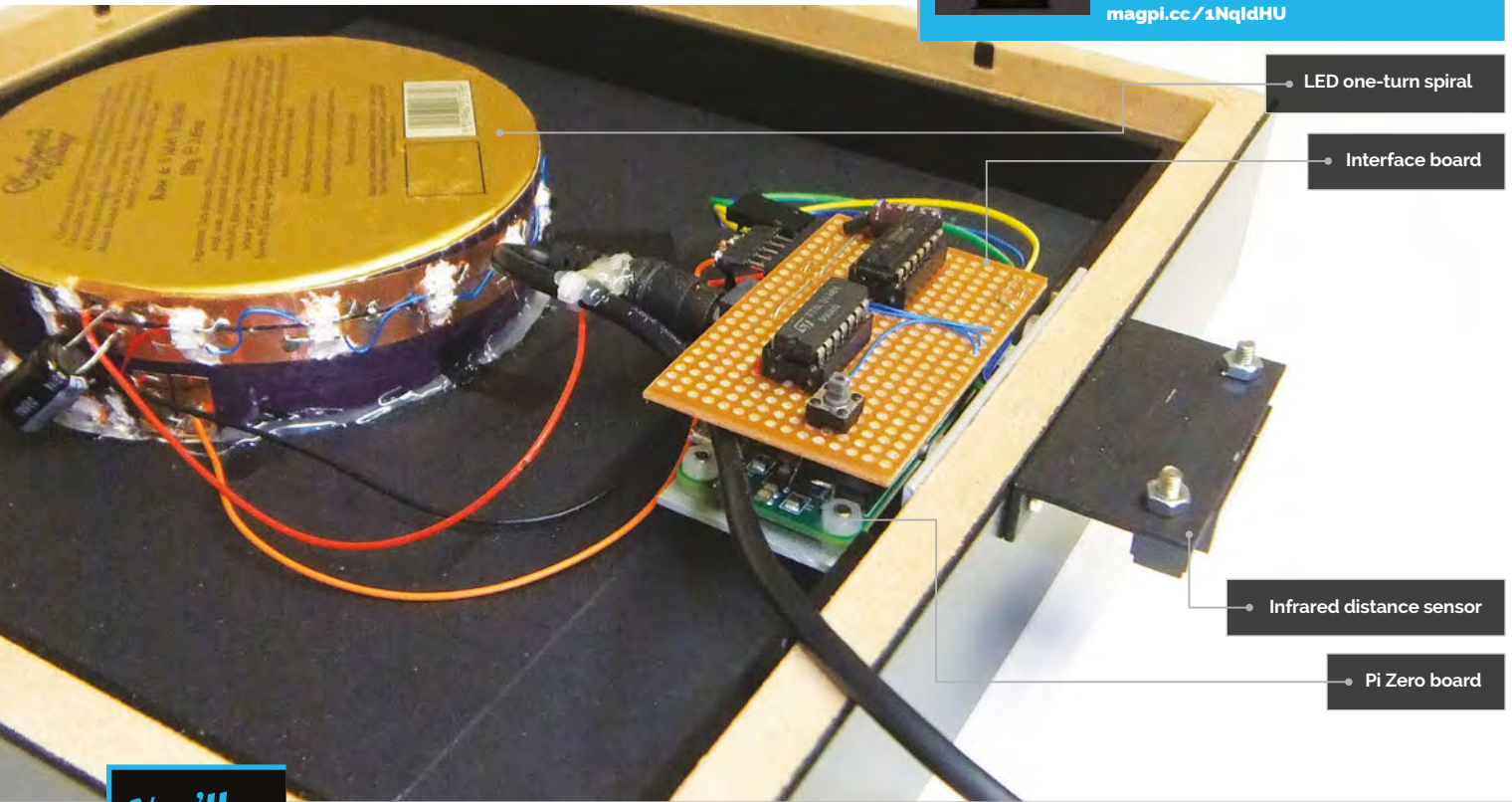

LED one-turn spiral

Interface board

Infrared distance sensor

Pi Zero board

## You'll Need

- > Raspberry Pi Zero
- > 16x WS2812b LEDs - through hole or surface mount
- > GP2Y0A2YK0F - IR distance sensor
- > LM339 comparator
- > 74LS14 - Hex Schmitt input buffer
- > Stripboard & self-adhesive copper strip
- > Ikea Ribba picture frame (000.780.51)
- > Two-way mirror film
- > Scrap CD or DVD
- > Connectors, leads, resistors, and capacitors

# INFINITY MIRROR

**PART 1**

The mirror that reacts to your presence and shows you infinity

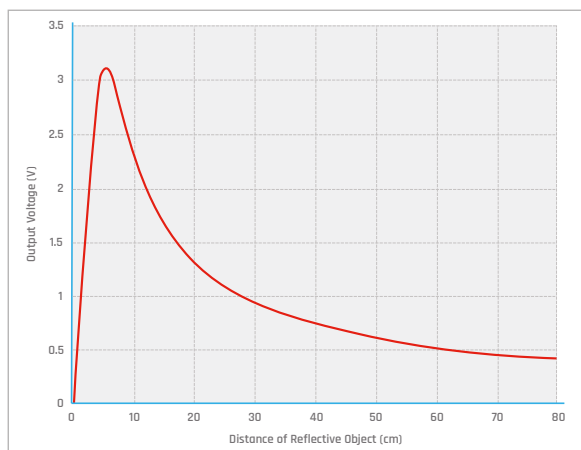

**Fig 1** The voltage output of the GP2Y0A2YK0F sensor

**T**he Raspberry Pi Zero is great for embedding in a project and just leaving it there, so we thought we would look at a project like this down at the Bakery. One project that has been on the books for some time is an Infinity Mirror: this is where you sandwich some LEDs between two mirrors and get reflections of reflections, all the way down to infinity. There have been a few published before, but not one like this. What's new about this one is that it has a unique arrangement of LEDs and reflecting surface, giving a different sort of pattern, as well as a distance sensor that triggers different patterns the closer you get to it.



The CD creates a refraction pattern

## The project

The project is based around an Ikea picture frame, the 23×23cm Ribba, with the front glass covered in two-way mirror film. There are basically two electronics circuits: the first one is the distance sensor based on the Sharp GP2Y0A2YK0F, and the second is a chain of WS2812b LEDs. The processor used in the Zero will run the Adafruit library for this chip, whereas the processor used in the Model 2 Pi is not currently compatible. The idea is that a strip of NeoPixels is arranged in a one-turn spiral on a tube, and at the bottom of the tube is a reflecting surface. We chose to make this a CD so that not only do you get a reflection, you also get a refraction pattern from the CD's optical grating, which splits the white and other secondary colours into their component parts.

## The design

**Fig 1** shows the output of the GP2Y0A2YK0F sensor for different distances. Note how this curve means that some readings are ambiguous – that is, one voltage reading could be one of two distances. However, this only happens for distances shorter than 5cm and in this application it's not a problem, even if the wrong distance is indicated. The output is analogue and the Pi has no built-in analogue to digital (A/D) converter, so we are going to have to make one. Fortunately, this does not need a very high resolution as we only want to indicate four different distance measurements. This can be done simply with four comparators arranged as a

## BUILDING THE MIRROR

### >STEP-01

#### Make the infinity tunnel

Find a large tube, about 10 to 12cm in diameter and 4cm deep, or you can roll one out of cardboard. Either way, roll your tube along a piece of paper to make a strip the same length as the circumference of the tube. Measure 5mm down from the top-right corner and 5mm up from the bottom-left corner, and draw a diagonal line between the two points. Fold the strip in half and straighten it out; where the crease mark cuts the line, mark a spot.

Repeat this procedure, folding to the halfway crease line for each side, to obtain two more creases; again, mark the intersection of the line and crease mark. You now have three equally spaced points along the diagonal line.

Repeat this action, folding to the other creases, until you have 16 points marked.

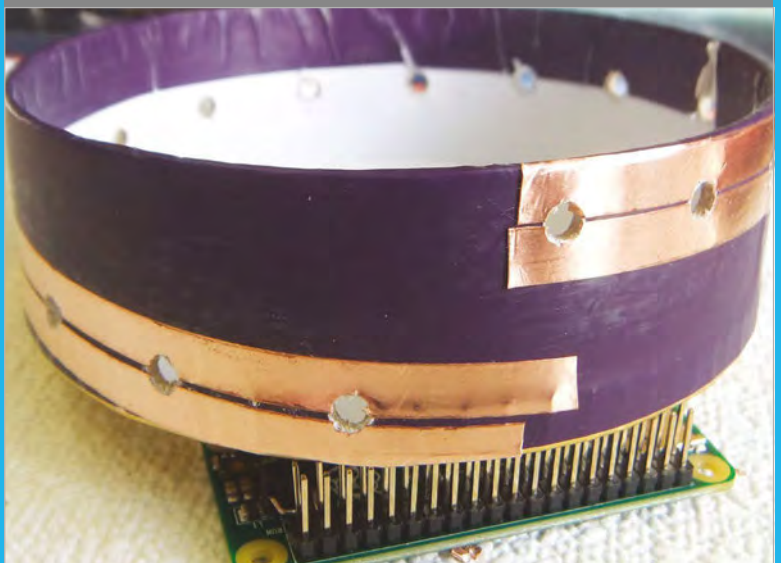

### >STEP-02

#### Prepare the tube

Glue this paper strip around the outside of the tube and drill a hole at each point. We made a support to place inside the tube to stop the drill press crushing the tube. Remove the paper strip and clean up the holes with a sharp knife. Paint the inside wall of the tube a matt black. Put a spiral of self-adhesive copper strip to join up the tops of the holes; make the strip pass just 0.5mm short of the hole's centre. Use a second strip to cover the bottom half of the holes; the two strips should be about 1mm apart. With a sharp knife, remove the copper that overhangs the holes.



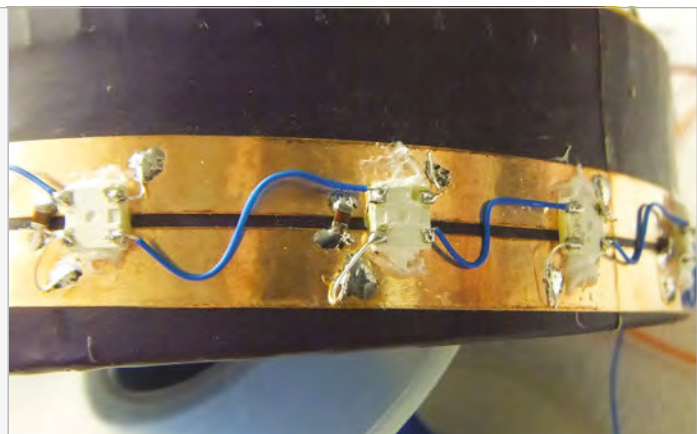
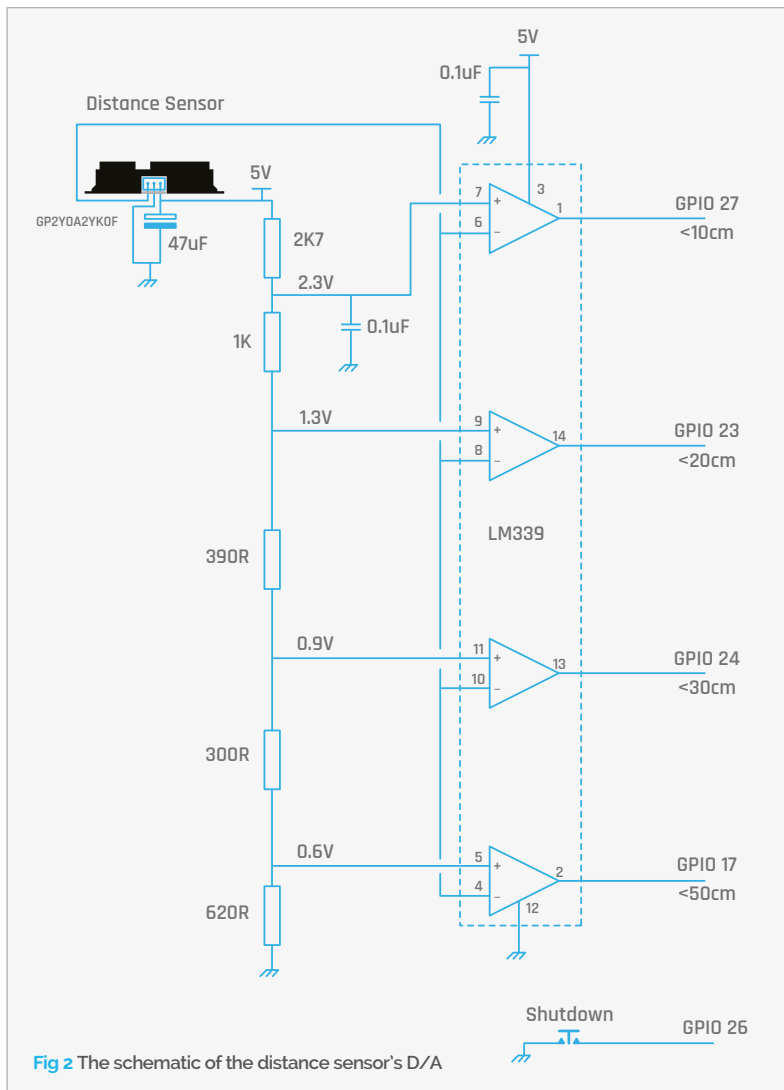

**Step 3** Wire up the LEDs

'flash converter'; the schematic is shown in **Fig 2**. The output of the sensor is fed to the negative input of all the comparators, and the positive input is fed by a chain of resistors across the 5V supply, giving various voltages at each node. The resistor values have been designed to produce voltages that correspond approximately to various distances, as shown in the diagram, so the output of the comparators gives you an indication of the distance. Note that if the distance is, say, 15cm, then the three bottom comparators will indicate the distance is <20, <30, and <50. The outputs are open collector, so they can be fed directly into the Pi's GPIO pins with their pull-up resistors enabled. Note also that there is a push button so that you can safely power down the project before removing the power supply.

The WS2812b or NeoPixel driver is shown in **Fig 3**. This is much the same as the one we used in the String Pong project in *The MagPi* #35, only the pin numbers have been changed to make the layout on stripboard

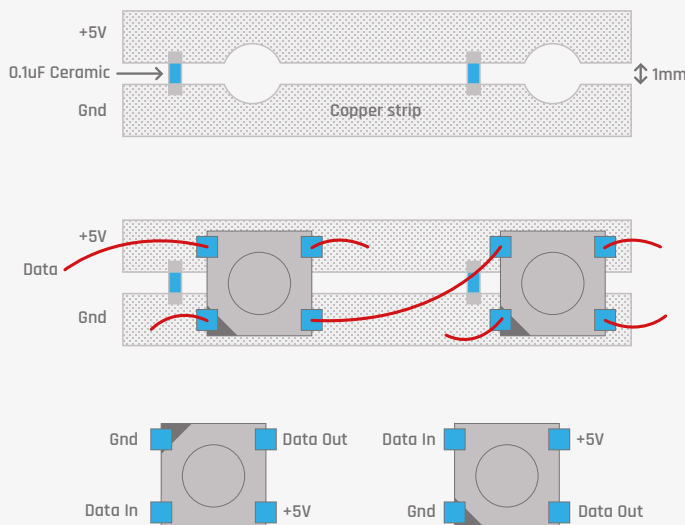

**>STEP-03**

**Wire up the LEDs**

Glue a WS2812b LED over each hole, making sure the diagonal edge marking the ground connection is next to the lower strip on the left-hand side. Hot-melt glue is good if you can be sparing with it, otherwise we used impact adhesive. Once the glue is dry, solder up the decoupling capacitors in front of each LED. Next, wire up the LEDs as shown in the diagram, with a wire going from the output of one LED to the input of the next; each LED is connected to the power or ground copper strip with a short length of wire. We used 28 AWG wire stripped of its insulation for this. Solder quickly to avoid damage to the LEDs. When complete, it's a good idea to test the LEDs with a program from the library's examples. Then the wires can be fixed and the LEDs reinforced with some hot-melt glue.

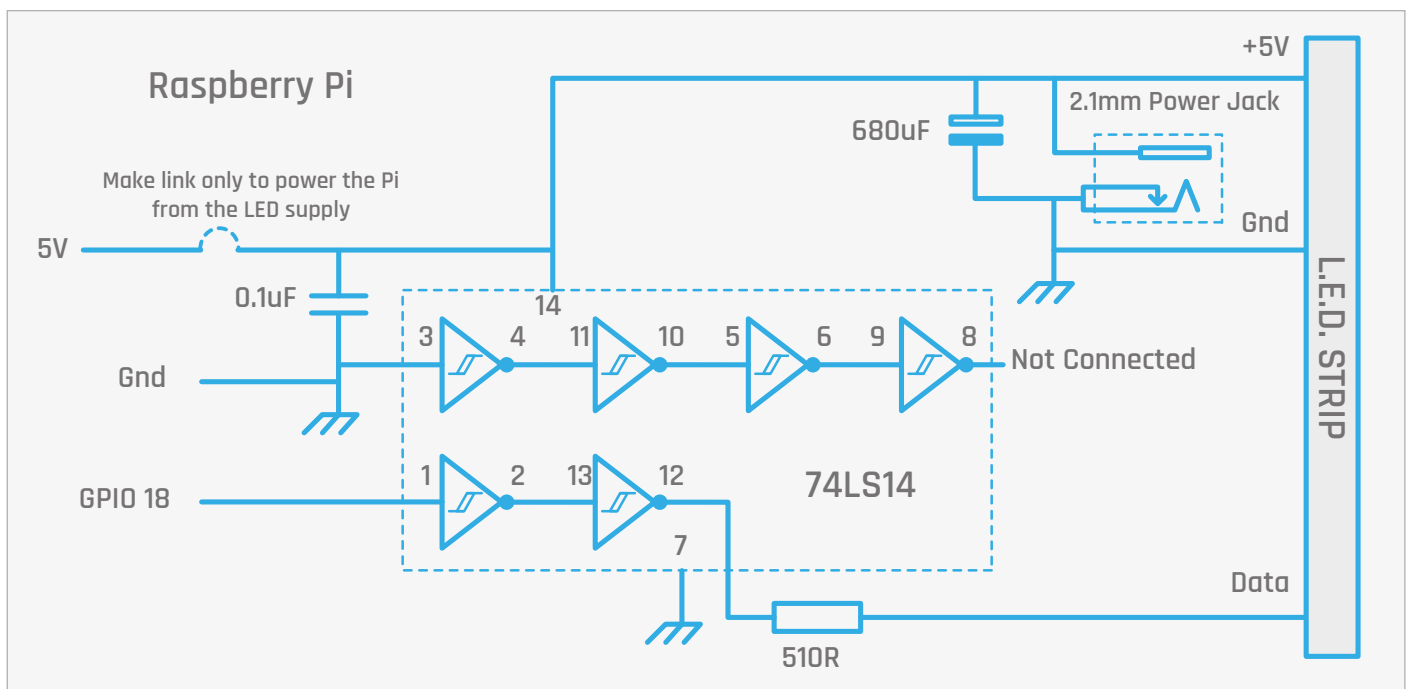

a bit easier. The LEDs can take over an amp, so they need powering separately. In fact, we powered the whole Pi Zero from this through a couple of 5V and ground pins on the GPIO connector. In case this is not what you do, you could have a removable link to the 5V line. For details of the construction, see the ‘Building the mirror’ step-by-step section.

## The software

You first need to install the Adafruit NeoPixel library. This link gives you step-by-step instructions on how to do this: [magpi.cc/1nRSyYk](http://magpi.cc/1nRSyYk).

The software has a simple job: to take the distance measurement from the sensor and use it to trigger one of four animations on the LEDs. These patterns are written as a state machine, so that at each step there's an opportunity to check if the distance has changed or the shutdown button has been pressed. The time between each step is determined by the `patternTimeSteps` list and can be changed to alter the speed. In order to shut down the Pi Zero safely, there's a push button that triggers a shutdown – press this before removing the power supply.

Fig 3 The schematic of the WS2812b LED driver

## >STEP-04

### Finish off the tube

Take a scrap CD or DVD with a good mirrored surface and use a disc sander to reduce its diameter so that it fits in the tube. At the very least, remove the clear band round the outside of the disc, as the mirror surface needs to be as close to the walls of the LED tube as possible. Cut another CD to make a patch to cover the hole in the CD, and use double-sided sticky tape to fix this to the base of the LED tube. Cut out a piece of black mounting foam to fit the picture frame; using a scalpel, cut a hole in the middle for the LED tube, allowing a bit of extra room to accommodate the LEDs sticking out.





## >STEP-05

### Make the brackets

Cover the picture frame glass with the mirror film. There are plenty of online examples of how to do this using a squeegee, water spray, and baby shampoo. Any specks of dust will show up, so make sure it's well cleaned. Note that it will take about a week for the film's glue to cure and bond with the glass. Fit the tube and mount flush with the mirror in the frame, and use a fillet of hot-melt glue to fix the light tube to the mount. Make a bracket to hold the distance sensor with a small piece of asymmetric angle aluminium and paint it black. Fix it on the bottom of the frame with two M3 bolts. Use these same bolts to fix the bracket that holds the Pi Zero and electronic interface. Fix the Pi Zero to the bracket using nylon nuts – we used drilled-out nylon nuts to make the stand-off pillars for the Zero to ensure there was no chance of the GPIO plug shorting out on the bracket.



## >STEP-06

### Finishing off

Finally, build the electronics – that is **Fig 2 & 3** – on a small piece of stripboard. We used pin headers soldered horizontally to make the connections with the LEDs and the distance sensor. Cut holes in the back mounting board to fix the LED disc in place.



The mirror's light patterns react to your proximity

## mirror1.py

```
01. # Magic mirror display
02. # By Mike Cook - January 2016
03.
04. import time, os, random
05. import wiringpi2 as io
06. from neopixel import *
07.
08. random.seed()
09. DATA_PIN = 18 # pin connected to the NeoPixels
10. NUM_PIXELS = 16 # number of LEDs in the spiral
11.
12. try :
13.     io.wiringPiSetupGpio()
14. except :
15.     print"start IDLE with 'gksudo idle' from CLI"
16.
17.
18. pixels = Adafruit_NeoPixel(
19.     NUM_PIXELS,DATA_PIN,800000,5,False)
20.
21. sensorPins = [17,24,23,27]
22. shutDownPin = 26
23. pattern = 0
24. patternTimeSteps = [0.5, 0.08, 0.05, 0.2, 0.01]
25.     # time spent in each step
26. patternStep = 0 ; patternTemp = 0 ;
27.     patternTemp2 = 0
28. col = [ (255,0,0),(0,255,0),(0,0,255),(255,255,255),
```

We used a Pi B+ to develop the code using the Pimoroni Black HAT Hack3R. When finished, we changed the `/etc/rc.local` file to add this line to the end:

```
python "path name"/mirror1.py &
```

This makes the Pi boot up automatically into this program. Of course, the 'path name' was replaced by the path where this program is to be found. This needs to be in quotes if there are any spaces in the path. Then we just swapped the SD card over to the Pi Zero and mounted it in the mirror.

### Taking it further

You can experiment and write your own LED display patterns that are triggered for each of the four distances the mirror can detect. You can even make the patterns multi-step – that is, the sequence of light could be extended, and change the longer the viewer is at a fixed distance.

In part 2 next issue, we will show you how to add a time display to the mirror, but all is not quite as straightforward as you might think. Tune in next month for a bit of a surprise.

```

26.         (255,0,0),(0,255,0),(0,0,255),(255,255,255) ]
27.
28. def main():
29.     initGPIO()
30.     while True:
31.         if io.digitalRead(shutDownPin) == 0 :
32.             os.system("sudo shutdown -h now")
33.             # to prepare for power down
34.             checkForDistance()
35.             advancePattern()
36.             time.sleep(patternTimeSteps[pattern])
37.
38. def advancePattern(): # next step in LED pattern
39.     global patternStep, patternTemp, patternTemp2
40.     if pattern == 0:
41.         return # nothing to do
42.     if pattern == 1 : # Radar scan
43.         if patternStep == 0:
44.             patternTemp +=1
45.             if patternTemp >3 :
46.                 patternTemp = 0
47.             wipe()
48.             pixels.setPixelColor(patternStep,Color(col[
49. patternTemp][0],col[patternTemp][1],col[patternTemp][2]))
50.             updateStep()
51.             return
52.         if pattern == 2 : # Colour wipe
53.             if patternStep == 0:
54.                 patternTemp +=1
55.                 if patternTemp >3 :
56.                     patternTemp = 0
57.                 pixels.setPixelColor(patternStep,Color(
58. col[patternTemp][0],col[patternTemp][1],col[
59. patternTemp][2] ))
60.                 updateStep()
61.                 return
62.             if pattern == 3 : # Multicolour riot
63.                 wipe()
64.                 off = patternStep & 0x03
65.                 for L in range(0,NUM_PIXELS,4):
66.                     pixels.setPixelColor(L, Color(
67. col[off][0],col[off][1] ,col[off][2] ))
68.                     pixels.setPixelColor(L+1, Color(
69. col[off+1][0],col[off+1][1],col[off+1][2]))
70.                     pixels.setPixelColor(L+2, Color(
71. col[off+2][0],col[off+2][1],col[off+2][2]))
72.                     pixels.setPixelColor(L+3, Color(
73. col[off+3][0],col[off+3][1],col[off+3][2]))
74.                     updateStep()
75.                     return
76.             if pattern == 4 : # Slow colour cycle
77.                 if patternStep == 0:
78.                     patternTemp += 5
79.                     if patternTemp > 255:
80.                         patternTemp = 0
81.                     pixels.setPixelColor(patternStep, Hcol(((
82. patternStep * 256 / NUM_PIXELS) + patternTemp) & 255))

```

```

75.         updateStep()
76.         return
77.
78. def initGPIO():
79.     for pin in range (0,4):
80.         io.pinMode(sensorPins[pin],0)
81.         io.pullUpDnControl(
82. sensorPins[pin],2)
83.         io.pinMode(shutDownPin,0)#input
84.         io.pullUpDnControl(
85. shutDownPin,2)
86.         pixels.begin()
87.         # This initialises the NeoPixel library
88.
89. def updateStep():
90.     global patternStep
91.     patternStep +=1
92.     if patternStep >= NUM_PIXELS :
93.         patternStep =0
94.     pixels.show()
95.
96. def wipe():
97.     for i in range(0,pixels.numPixels()):
98.         pixels.setPixelColor(i, Color(0,0,0))
99.
100. def Hcol(h): # HSV colour space with S = V = 1
101.     if h < 85:
102.         return Color(h * 3, 255 - h * 3, 0)
103.     elif h < 170:
104.         h -= 85
105.         return Color(255 - h * 3, 0, h * 3)
106.     else:
107.         h -= 170
108.         return Color(0, h * 3, 255 - h * 3)
109.
110. def checkForDistance(): # select pattern based on distance
111.     global pattern, patternStep
112.     if io.digitalRead(sensorPins[0]) == 1 :
113.         if pattern != 0: # if something showing
114.             wipe()
115.             pixels.show()
116.             pattern = 0 # stop any display
117.             patternStep = 0 # put to start of a pattern
118.         else :
119.             close = 0
120.             for n in range(1,4):
121.                 if io.digitalRead(sensorPins[n]) == 0 :
122.                     close = n
123.             if pattern != close+1 : # has pattern changed?
124.                 pattern = close+1
125.                 patternStep = 0 # stage in pattern
126.                 #print"now showing pattern",pattern
127.
128. # Main program logic
129. if __name__ == '__main__':
130.     main()

```

Language

&gt;PYTHON 2.7

DOWNLOAD:  
magpi.cc/1NqJjmVPROJECT  
VIDEOSCheck out Mike's  
Bakery videos at:  
magpi.cc/1NqJnTz



**JAMES SINGLETON**

James is a developer, engineer, and author. He helps people find software jobs in the environmental sector with 'Cleanweb Jobs'.  
[unop.uk](http://unop.uk)  
[cleanwebjobs.com](http://cleanwebjobs.com)

It's all powered by the Raspberry Pi, timed to go off when you need it to



A discarded globe from a charity shop is the perfect thing to create the wake-light

The main light for the alarm is much brighter than the Sense HAT LEDs



**You'll Need**

- > Sense HAT [magpi.cc/1TGGUt5](http://magpi.cc/1TGGUt5)
- > BlinkyTape LED strip (or NeoPixel / DotStar)
- > An unwanted globe
- > Plastic bottle
- > Sticky pads
- > Blu-Tack or putty

# PI GLOWBE

## THE PI-POWERED WAKE-LIGHT

Turn a globe into a glowing orb and use it to help you wake up in the dark winter months

**D**uring the winter, or even at any time of the year, it can be difficult to get up in the mornings. If you wake before dawn, your body still thinks it's night (because it is). You can buy wake-lights that trick your body into waking up by simulating a fake sunrise; they get gradually brighter as your alarm approaches. These can be quite expensive, so why not make your own with a Pi and some LEDs? To celebrate the Astro Pis on the ISS, we've built one using a Sense HAT inside a globe that was found in a charity shop – perhaps an unwanted Christmas present, now repurposed!

### >STEP-01 Make an LED bulb

Create a bulb by wrapping an LED strip around a plastic bottle. You could skip this, but the Sense HAT is not bright enough to make a lamp. Cut the top off an empty plastic bottle, cover it in sticky pads and wrap the LED strip around it in a spiral. You can secure the ends further with tape. Have the connection end at the wider opening so that you can route the power cable to the Pi and then out through the centre. We'll mount the Pi on top of the upside-down bottle end, so ensure it's flat.



## >STEP-02

### Destroy the world

Remove the Earth from its mount by pulling the pegs of the holder out of the holes in the Arctic and Antarctic. Next, split it in half along the equator by pulling the two hemispheres apart. It should disassemble fairly easily with a little force applied in the correct places. You'll want to fashion a new mount to stop the globe rolling around, whilst still allowing the power cable to exit from the bottom hole - you could use the inside of a roll of tape. You can cut a small slot with a knife to allow the wire to enter.

## >STEP-03

### Mount inside globe

Attach your new LED bulb to the inside of the globe. Mount the neck of the bottle over the lower hole with Blu-Tack or putty; it should be sturdy enough to support the weight of the Pi resting on top of it. Mount the Sense HAT on the Pi, and then place both on top of the upturned bottle. Attach a USB WiFi dongle to the Pi (unless you're using wired Ethernet), otherwise it will wake you at the wrong time. This is because the Pi requires internet access to set its clock.

## >STEP-04

### Route the power

You'll probably need to cut and reconnect the power cable to fit it through the hole. The official Pi power supply uses bell wire, which makes it easy to reconnect with a screw terminal (choc block). Unfortunately, it doesn't supply enough power to use the LEDs at full brightness and also run the Pi. Cut the cable and insert the supply end through the hole. Tie a knot in the cable to stop it from being pulled back through. Separate the two power cores from both ends and strip the insulation. Reconnect with a choc block, matching the polarity.

## >STEP-05

### Download the code

Clone the code from the GitHub repository into your home folder:

```
git clone https://github.com/jpsingleton/pi-glowbe.git
```

If you're only using part of the hardware or a different LED strip, you can adapt the code to your needs. You may also need to install the Sense HAT software if you're running an older version of Raspbian - follow the instructions at [magpi.cc/1KboHnN](https://magpi.cc/1KboHnN). You may also want to disable the LEDs on the Pi so they don't disturb your sleep. Newer models can do this in software, otherwise you could tape over them, or even de-solder them if you're brave enough.

# wakeup.py

```
from BlinkyTape import BlinkyTape
from sense_hat import SenseHat
from time import sleep
import optparse
```

```
# Default Blinky Tape port on Raspberry Pi is /dev/ttyACM0
parser = optparse.OptionParser()
parser.add_option("-p", "--port", dest="portname",
                  help="serial port (ex: /dev/ttyACM0)",
                  default="/dev/ttyACM0")
(options, args) = parser.parse_args()
```

```
if options.portname is not None:
    port = options.portname
else:
    print "Usage: python wakeup.py -p <port name>"
    print "(ex.: python wakeup.py -p /dev/ttyACM0)"
    exit()
```

```
sense = SenseHat()
bt = BlinkyTape(port)
```

```
# wake phase - gradually get brighter, linearly
sleepTime = 18 # 18 sec for 30 min in 100 steps
maxPower = 100 # flickers or cuts out above 100
```

```
for y in xrange(maxPower):
    sense.clear(y * 2, y * 2, y * 2)
    for x in xrange(sleepTime):
        bt.displayColor(y, y, y)
        sleep(1)
```

```
# on phase - at full brightness for the same time
sense.clear(255, 255, 255)
for z in xrange(maxPower * sleepTime):
    bt.displayColor(maxPower, maxPower, maxPower)
    sleep(1)
```

```
# tidy up
sense.clear()
```

## >STEP-06

### Set up your schedule

We'll run the code with cron. It should start about half an hour before you get up and probably only on weekdays. Launch the cron configuration by typing the following into a terminal:

```
crontab -e
```

Next, set it up by adding the following line to the end:

```
15 6 * * 1-5 python /home/pi/pi-glowbe/wakeup.py
```

This will run the code every weekday at 06:15, so change it to meet your needs. Save the file and exit the editor (CTRL+X, Y, then ENTER in the default nano). Once happy, reassemble everything and wait for morning!

Language

&gt;PYTHON 2.7

DOWNLOAD:

[magpi.cc/1TUKdz7](https://magpi.cc/1TUKdz7)



**OZZY HAYLER-GOODALL**

When Ozzy is not coding experiments for the ISS, he's playing rugby or being a junior mentor at CoderDojo Ham. He's nine years old.  
**CoderDojoHam.org**



The roof stops you looking down and seeing where the bedrock's shadow is

Try not to fall down those holes on the way!

Here's the timer – you have 80 seconds to get to the other side in our version

# THE BEDROCK CHALLENGE

How good is your intuition? Can you navigate your way through an invisible arena?

## You'll Need

- > LED
- > Jumper wires
- > Breadboard
- > 220-ohm resistor

**I**magine you're building your house in *Minecraft*, minding your own business, when suddenly you're teleported high in the air. You're forced to compete in the Bedrock Challenge. If you fail to get to the other side of the arena, you plummet to your doom! Have a go at coding your own Bedrock Challenge, see if your friends can complete it, and have a go yourself.

The Bedrock Challenge is a game where the goal is to get to the other side of the invisible bedrock grid without falling down the holes. The catch is that there's a wooden roof so you can't see the light shining through the holes onto the ground, where invisible bedrock would cast a shadow.

You can't cheat by jumping or flying because if you do, you get teleported back to the start. The only help you get is an LED which will light up if there's a hole in any of the nine blocks around you, but not the one you're on.

We use the Python library PyAutoGUI, which can cause a key to be pressed down or released. We also use another library called 'threading', which lets us run something while other parts of the program are working. Other libraries are used, but we don't have to install them because they are standard Python libraries.

### Get prepared

Here's how you install PyAutoGUI. Open a terminal and type the following into it:

```
sudo pip3 install pyautogui
```

Next, install threading:

```
sudo pip3 install threading
```

Finally, python3-xlib, as required by PyAutoGUI:

```
sudo apt-get install python3-xlib
```

Now we're on to the wiring: you need to connect the LED to the Raspberry Pi. Build the circuit as shown in

**Fig 1** Here's the circuit that lights up the LED. It's very simple, only requiring an LED and a resistor

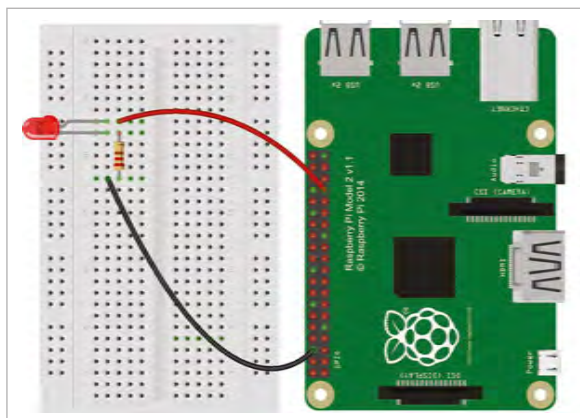

# bedrockchallenge.py

```

from gpiozero import LED
from mcpi.minecraft import Minecraft
import time, sys, random, threading
import pyautogui as pag
led = LED(13)
mc = Minecraft.create()
running = True
def make_holes(num, x, y, z): # make the holes
    for I in range(num):
        rx = random.randint(2,49)
        rz = random.randint(2,49)
        mc.setBlocks(x+rx, y+20, z+rz, x+rx, y+22, z+rz, 0)
def monitor(starting_pos):
    global running
    LED = [(-1, -1, 1), (-1, -1, 0), (-1, -1, -1), (
0, -1, -1), (1, -1, -1), (1, -1, 0), (1, -1, 1), (0, -1, 1)]
    y_start = starting_pos.y
    while running:
        pag.keyUp('shift')
        pos = mc.player.getTilePos()
        for p in LED:
            boss = mc.getBlock(pos.x+p[0], pos.y+p[1], pos.z+p[2])
            if boss==0:
                led.on() # LED on
            else:
                led.off() # LED off
        if pos.y > y_start:
            mc.postToChat ('cheat')
            mc.player.setPos(
starting_pos.x, pos.y, starting_pos.z) # teleport after cheating
            time.sleep(1)
        if pos.y < y_start:
            mc.postToChat ('Uh-oh')
            time.sleep(3)
            mc.player.setPos(
starting_pos.x, starting_pos.y, starting_pos.z)
            # move after cheating
        if pos.z==starting_pos.z+51:
            mc.postToChat('Well Done')

        running = False
try:
    pos = mc.player.getTilePos()
    mc.postToChat(
'get ready for the bedrock challenge')
    time.sleep(1)
    mc.postToChat(
'get to the other side without falling
down the holes!')
    time.sleep(3)
    mc.setBlocks(
pos.x+1, pos.y+20, pos.z, pos.x+53, pos.y+22, pos.z+53, 35) #wool
    mc.setBlocks(
pos.x+2, pos.y+20, pos.z+1, pos.x+52, pos.y+20, pos.z+52, 95)#bedrock
    mc.setBlocks(
pos.x+1, pos.y+30, pos.z, pos.x+53, pos.y+30, pos.z+53, 17) #roof
    mc.setBlocks(
pos.x+2, pos.y+21, pos.z+1, pos.x+52, pos.y+22, pos.z+52, 0)
    # air for Steve starting position
    mc.setBlocks(
pos.x+25, pos.y+21, pos.z+1, pos.x+25, pos.y+22, pos.z+1, 0)
    mc.player.setPos(
pos.x+25, pos.y+21, pos.z+1) # teleport to start
    newpos = mc.player.getTilePos() # get new position
    t1 = threading.Thread(target = monitor, args = (newpos, ))
    t1.start()
    make_holes(250, pos.x, pos.y, pos.z)
    time_start = time.time()
    counter = 80 # setting the timer
    while time.time()<time_start+80: # starting the timer
        time.sleep(1)
        counter-=1
        if counter%10==0:
            mc.postToChat(str(counter))
    mc.setBlocks(
pos.x+2, pos.y+20, pos.z+1, pos.x+52, pos.y+20, pos.z+52, 0)
    mc.postToChat('GAME OVER')
    running = False
except KeyboardInterrupt: # type Ctrl+C
    print('bye')
    running = False
    sys.exit()

```

Language

&gt;PYTHON 3

**DOWNLOAD:**  
[magpi.cc/1QbdoYO](http://magpi.cc/1QbdoYO)

**Fig 1.** To test it, open a terminal and type **python3**, then enter the following lines:

```

from gpiozero import LED
led = LED(13)
led.on()

```

This should turn on the LED assigned to GPIO pin 13.

## Modding Minecraft

Now we've done all our preparations, let's get coding! In this code, we have two functions: one stops you cheating while the other creates the holes. There are two main ways of cheating, and we block both of these. One way is to hold down the **SHIFT** key ('enable sneak'), which normally stops you falling. We use PyAutoGUI to hold the **SHIFT** key up to prevent you from using sneak. The other way is to fly to the finish. We stop this by finding your Y position at the start, then checking if it has changed - in other words, if you've gone higher. It also won't allow you to run

around the perimeter walls. The function that stops you cheating has another purpose: it turns the LED on if there's air around you. We do this by finding the positions of all nine blocks, then we see if one of them is air. If one or more is air, we turn the LED on. If you do sadly fall down a hole, 'Uh-Oh' gets displayed and you'll be teleported back to the start.

Here's how we create the arena. We first build the invisible bedrock plane, then we pick random positions to place the holes. After that, we build the roof, and then finally we create the wool walls. To give you a time limit to reach the other end we have a counter, which gets displayed on the *Minecraft* screen when it reaches a multiple of ten. When it reaches zero, we turn all the invisible bedrock into air. Game over!

You could make it easier by giving the player more time, or make it harder and have more holes. If you have an annoying older brother, they might find some other sneaky ways to cheat. Can you think of any? If you can, try to write code to prevent them!



**RICHARD HAYLER**

Richard is a mentor at CoderDojo Ham. His school Code Club was one of the winning teams in the Primary Astro Pi competition who now have their code on the ISS.  
[richardhayler.blogspot.co.uk](http://richardhayler.blogspot.co.uk)  
[@rdhayler](https://twitter.com/rdhayler) / [coderdojoham.org](http://coderdojoham.org)

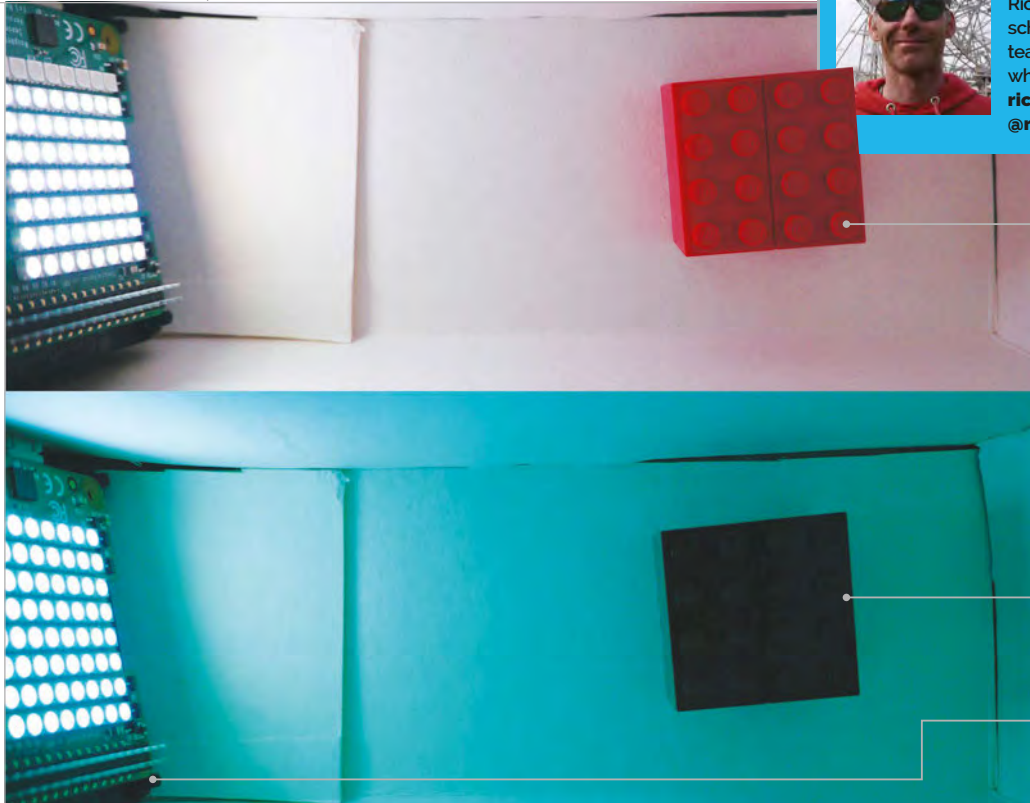

Under white light, the Lego blocks look red, just as we normally see them

Remove the red component from the light and the blocks appear black, because there is no longer any light scattered from them

Use the HATColourSlider widget to gradually change the light colour in your box

# SENSE HAT SCIENCE: LIGHT AND COLOUR

**PART 01**

Why is grass green? Why do we see objects as having different colours? With your trusty Sense HAT, you can carry out a simple experiment to investigate the properties of light and colour

**You'll Need**

- > A Sense HAT (or a Unicorn HAT) [magpi.cc/1TGGUt5](http://magpi.cc/1TGGUt5) (or [magpi.cc/1PCpRZ5](http://magpi.cc/1PCpRZ5))
- > An old cereal box, scissors and sticky tape
- > HATColourSlider [magpi.cc/1okQVCt](http://magpi.cc/1okQVCt)
- > Some small objects of different colours

**R**aspberry Pi isn't just about coding and learning programming languages. By attaching additional hardware, the Pi can act as a platform for all sorts of scientific investigations. The best example of this is the Sense HAT. This fantastic device is bristling with sensors, perfect for performing fun science experiments in the classroom, at home, or even on your orbiting space station. In this first Sense HAT Science feature, we're going to look at the LED matrix and some simple ways of demonstrating the ideas of a colour spectrum of light, and why different objects are different colours.

**THE ELECTROMAGNETIC SPECTRUM**

Visible light is just one type of electromagnetic radiation. There are various types, some with longer wavelengths than visible light (e.g. radio waves) and some with shorter wavelengths (X-rays, for example).

**Programming the lights**

The LED matrix on the Sense HAT has 64 elements made up of three separate LEDs - red, green, and blue - in a single housing. We can illustrate this in Python. Open IDLE3, load the SenseHat library and connect to the board:

```
from sense_hat import SenseHat
sh = SenseHat()
```

We can turn on all the LEDs with a single command:

```
sh.clear(255,0,0)
```

The three numbers in the brackets of the command represent the brightness of the three colours (in the order R, G, B and with 255 being maximum intensity), so this should switch on all the red LEDs but leave the green and blue ones off. To turn on just the green LEDs, type:

Blue LED  
460 - 480nm

Green LED  
52 - 540nm

Red LED  
619 - 624nm



400

Wavelength in nm

700

```
sh.cclear(0,255,0)
```

You can do this in Scratch, too – see **Fig 1** below. We can also mix colours to create other shades, much like paint:

```
sh.cclear(175,100,200)
```

This should produce a pleasant pale pink colour. You can do the same thing using Scratch, but you have to use hexadecimal notation to specify the colour values (**Fig 1** again).

To make it easier to quickly mix the colour settings for the Sense HAT LEDs, you can download a simple widget. Back in a terminal window, type:

```
git clone https://github.com/topshed/HATColourSlider.git
```

Then change into the newly cloned directory and copy the desktop shortcut into place:

```
cd HATColourSlider
cp HATColourSlider.desktop ~/Desktop
```

Double-click on the icon that will have appeared on your desktop and use the sliders to mix the red, green, and blue light.

If you turn all three colours to their maximum, you should see that the LEDs produce white light.

### For science!

Back in 1665, Isaac Newton was the first to prove that white light is made up of all the colours that we can see: he took a glass prism and placed it in a sunbeam, producing a spectacular multicoloured spectrum like a rainbow. Light waves are refracted as they enter and exit the prism. The shorter the wavelength of the light, the more it is refracted. As a result, red light is refracted the least and violet light is refracted the most, causing the coloured light to spread out to form a spectrum. We can think of the LEDs in the Sense HAT as performing this process in reverse – combining the colours to produce white light.

We can also use the Sense HAT’s ability to produce different-coloured light to investigate why objects appear as different shades. Find a box big enough to hold the Raspberry Pi and Sense Hat, and which has a top that you can close. Half a cereal box is an ideal size for this purpose: cut a slot along one

corner to allow the power and HDMI cables to remain connected. Now find a bunch of small, different-coloured objects that will fit in the box (Lego blocks are perfect). Make sure you have red, green, and blue objects.

This works best in a dark room; close the flaps on the top of the box to prevent as much external light as possible entering from the monitor, while leaving a small gap that you can peer through.

Start with a red object. Illuminate it in the box with all LEDs set to maximum (i.e. white light). Now reduce the brightness of the red LEDs down to zero. The ‘redness’ of the block should fade until it appears black. Try the same experiment with blue and green coloured objects, observing what happens when you remove that colour from the light emitted by the LEDs.

### Conclusive evidence

Why does this happen? An object appears to have a colour because it is able to selectively absorb and reflect certain wavelengths of visible light. An object will appear white if it does not absorb any wavelength of visible light and all the light that falls upon it is scattered back to our eyes. An object will have a red colour when it absorbs all wavelengths of visible light except for red. Just the red light is scattered to our eye, so the object looks red. However, as you can demonstrate with the Sense HAT, if we remove the red component of white light that falls on a red object, there is nothing to be scattered back and so the object will appear black. From this we can also see that a black object will therefore be one which absorbs all the wavelengths of the light falling on it.

So what about grass? Like many plants, it produces a bright pigment called chlorophyll which absorbs blue and red light well, but mostly reflects green light. Now you know!

**Above** Each colour LED produces light at a small range of wavelengths. The closer in colour an object is to this wavelength, the ‘blackier’ it will appear when that component is removed

### HEXADECIMAL

Hexadecimal is a base 16 number system. A hex digit can be any of the following 16 digits: 0 1 2 3 4 5 6 7 8 9 A B C D E F. So 175 is 0xAF, 100 is 0x64, and 200 is 0xC8.

**Fig 1** If you want to specify exotic colour combinations in Scratch, you need to use hex notation

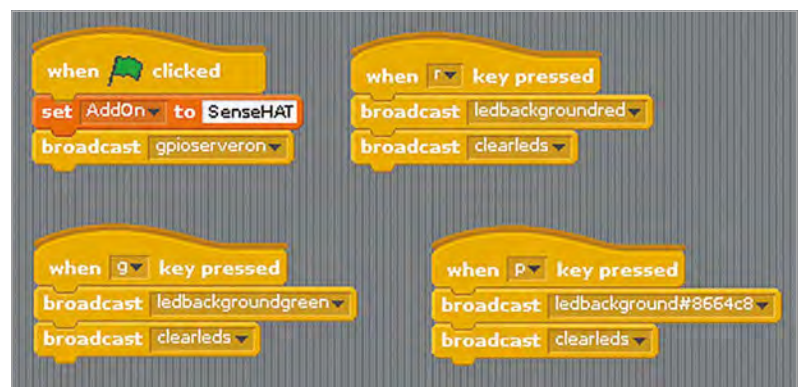

# FREQUENTLY ASKED QUESTIONS

## NEED A PROBLEM SOLVED?

Email [magpi@raspberrypi.org](mailto:magpi@raspberrypi.org) or  
find us on [raspberrypi.org/forums](http://raspberrypi.org/forums)  
to feature in a future issue.

Your technical hardware and software problems solved...

### WHAT'S THE BEST NORMAL OPERATING SYSTEM?

#### Raspbian

The official operating system for the Raspberry Pi is made to be easy to use and comes with a lot of tools for teaching and learning. It supports all the hardware functions of the Raspberry Pi first, and usually by default as well.

#### Ubuntu MATE

Based on the wildly popular Linux distribution Ubuntu, Ubuntu MATE uses the MATE desktop environment on top of an optimised version of Ubuntu for the Raspberry Pi. If you're looking for a pure desktop experience, Ubuntu MATE is worth a look.

#### Arch Linux

A very small operating system that comes with the bare-bones to get the Raspberry Pi running. If you need a lightweight, quick OS that makes the most of the Raspberry Pi's power and don't mind working in the command line, this is the one for you.

### I'M HAVING PROBLEMS UPDATING RASPBIAN

#### Fill the SD card

From the configuration menu for Raspbian, there's an option to expand the file system to fill the SD card. If you're running out of space from the basic image, you may not be able to download updates properly to install them. This will generally fix it.

#### Disable software sources

If you notice the Raspberry Pi hanging on specific packages while updating and can't wait, you may need to go into the Software Sources list and disable that specific repository and then run the update again. It will skip the troublesome packages.

#### Reinstall

Unfortunately, if it's just not updating or working properly, you may just need to reinstall Raspbian to the SD card, possibly because it didn't install properly in the first place. Re-download the image or NOOBS version you're using, back up any data on the card, and try again.

### WHAT OPERATING SYSTEM IS GOOD FOR MEDIA CENTRES?

#### OpenELEC

OpenELEC runs Kodi, which used to be called XBMC, and is heavily optimised to be fast on anything it runs on. If you want the pure Kodi experience and just a decent, low-hassle HTPC, OpenELEC is an excellent choice to help get you started.

#### OSMC

While OSMC uses Kodi as a base, it has its own interface and extra features added on top to make it a little different, and in some ways a bit more user-friendly. It also installs very easily and quickly.

#### Raspbian + Kodi

Installing Kodi on Raspbian is a great way to have a multipurpose Raspberry Pi. It won't run as well as OpenELEC or even OSMC, but you can switch between HTPC mode and normal desktop mode.



# FROM THE RASPBERRY PI FAQ RASPBERRYPI.ORG/HELP

## What system on a chip is used in the Raspberry Pi?

All versions and revisions of the Raspberry Pi other than the Raspberry Pi 2B and 3B use the Broadcom BCM2835. This contains an ARM1176JZF-S with floating point, running at 700MHz, and a VideoCore IV GPU. The GPU is capable of Blu-ray-quality playback, using H.264 at 40Mbps. It has a fast 3D core, accessed using the supplied OpenGL ES2.0 and OpenVG libraries. The Model 2B uses the Broadcom BCM2836. This contains a quad-core ARM Cortex-A7 processor with floating point and NEON, running at 900MHz, and the same VideoCore IV GPU that is in the other models of Raspberry Pi. The Model 3B uses a Broadcom BCM2837, which again is a quad-core processor, although this one is based on the 64-bit ARM Cortex-A53 and clocks at 1.2GHz per core. It too has a VideoCore IV GPU.

## What is a system on a chip?

A system on a chip (SoC) is a method of placing all necessary electronics for running a computer on a single chip. Instead of having an individual chip for the CPU, GPU, USB controller, RAM, Northbridge, Southbridge, etc., everything is compressed down into one tidy package.

## Why did you select the ARM1176JZFS?

Cost and performance.

## Do you make a self-assembly kit of the Raspberry Pi?

No. It would be too expensive for us to provide kits alongside finished boards, which would mean introducing another step in manufacturing; and a kit would be impossible to hand-solder. We use special equipment (robots!) to solder on the BGA package and other tiny components.

# WWW.PI-SHACK.COM

The best Raspberry Pi products and accessories, all under one roof with low cost UK shipping

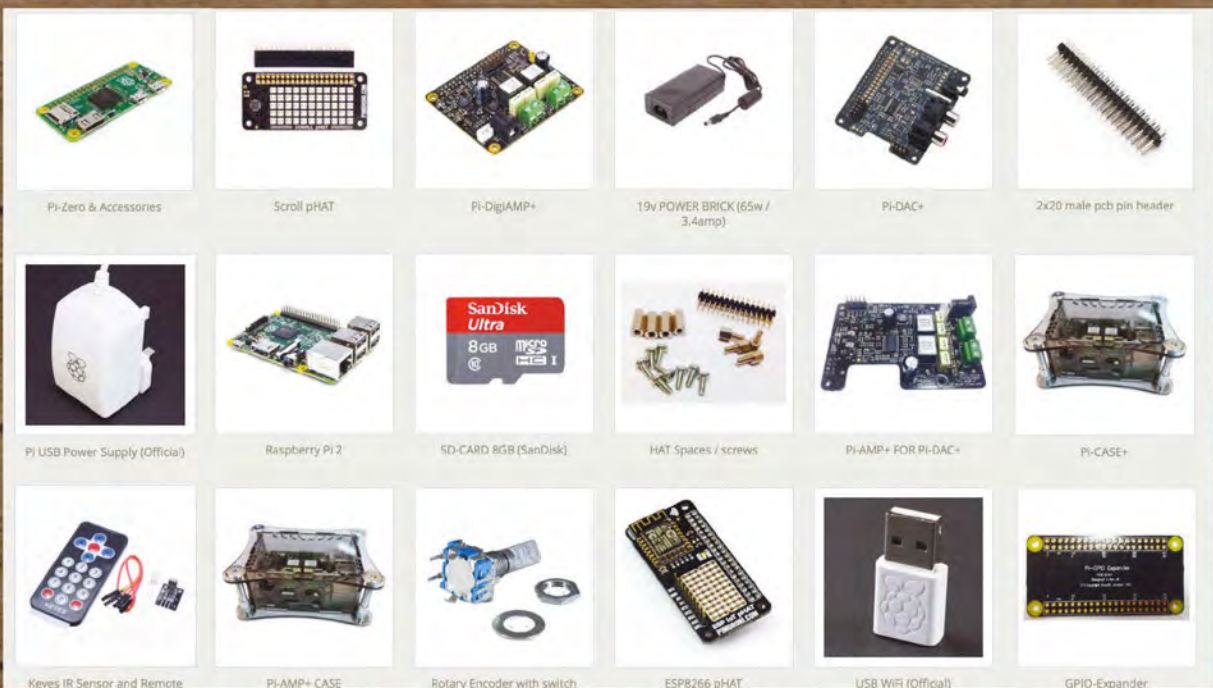

Twitter: @ThePiShack  
 Email: info@pi-shack.com  
 Tel: +44 7413 039894

open source  
hardwareOpen Source  
Initiative

# FREE TO SHARE

**Richard Smedley's** cut-out-and-keep guide on how (and why) you should give your next Raspberry Pi project an open-source licence...

**F**irst comes the urge to make, strong enough to get you past sensor glitches, Pi peculiarities, and nearly untraceable software bugs. As your project's smart-looking case comes together with an almost-functioning prototype, then comes the urge to share. Carried by the feelings of joy and satisfaction that accompany a successful build, you even make a decent stab at documentation; time to publish online somewhere. Hold on, there's something we haven't thought about yet: the licence.

In most countries since the Berne Convention of 1886, publishing anything – including software – will automatically put it under copyright, preventing anyone from redistributing it without permission. Open-source licences are designed to make it easy to share your software and hardware with the community of makers, allowing other people to have fun building your project, then maybe adding their own modifications and putting them online for others to build on – derivative works, in licensing speak – and giving you back a few ideas for the next iteration. The situation with hardware is nowhere near as straightforward as software, and we'll get onto that later, as well as a few things to bear in mind when licensing documentation, but first, let's look at software licences.

The open-source world thrives on choice, yet the number of licences available is bafflingly huge – 70 on the OSI-approved list alone. The historic reasons for this are long and vexed (see 'Free or Open?' boxout), but the choices are simpler than they seem, and come down to a straightforward question: when somebody modifies your design and makes those changes available in some product or design form, would you like them to share those modifications with the community in the same way that you have, or would you like them to be free to do what they want – even keeping changes secret, and selling the results?



## Free to share

Enforcing sharing through licences is known as copyleft, and the best-known copyleft licence is the GNU GPL – used for much of Raspbian and all of its other GNU/Linux relatives. The GNU General Public License (GPL) is one of the oldest FOSS licences, and was the first designed to ensure both the freedom of the end user and that of users further down the chain, after software had been modified and passed on.

The Free Software Foundation (FSF) and the GNU project were both started in the 1980s by Richard Stallman, who wrote GNU Emacs and the GNU toolchain, including the GNU Compiler Collection's (GCC) C compiler, which is the first piece of software that chip manufacturers port to any new

“ Enforcing sharing through licences is known as copyleft ”

hardware platform. While the GNU project – at least with the addition of the Linux kernel – has grown to dominate every area of serious computing, the copyleft ideas behind the GPL have had an effect in several fields beyond computing – from farming ([opensourceecology.org](http://opensourceecology.org)) to medicine ([opensource.com/tags/medicine](http://opensource.com/tags/medicine)). The key to copyleft is protecting ‘four essential freedoms’:

- > The freedom to run the program as you wish, for any purpose (freedom 0).
- > The freedom to study how the program works, and change it so it does your computing as you wish (freedom 1). Access to the source code is a precondition for this.
- > The freedom to redistribute copies so you can help your neighbour (freedom 2).
- > The freedom to distribute copies of your modified versions to others (freedom 3). By doing this, you can give the whole community a chance to benefit from your changes. Access to the source code is a precondition for this.

All of this can be summarised as ‘I’m going to let you do what you like with my program – *providing* that when you pass it along (with or without your own modifications), you pass on these same freedoms

opensource.com CC-BY-SA



## Open Source Initiative

### FREE OR OPEN?

English, despite its monstrously large vocabulary, is one of the only languages to conflate the meanings of free-of-charge and free-as-in-speech into the same word. Consequently, free software in the early days was often lumped with freeware, shareware, and other proprietary but often amateur small projects. The approach of the Free Software Foundation (FSF) to this problem (for the English-speaking world) is to talk continuously about freedom until the message gets through.

A different approach was taken by some members of the GNU/Linux community at the end of the 1990s, coining the term ‘open source’ in an effort to find a business-friendly alternative to ‘free’. Their early rhetoric tended to emphasise the benefits of access to the source code, which led to some muddying of the waters when some proprietary companies allowed limited access to their source code, but under very restrictive terms.

The term FOSS (free and open-source software) nowadays means we can all talk about the same thing, without bickering about words. The Open Source Initiative's ‘Open Source Definition’ [1] (based on Bruce Perens's Debian Free Software Guidelines of 1997) emphasises freedom to modify and redistribute every bit as much as the Free Software Definition [2] written for the FSF by Richard Stallman 30 years ago.

- > [gnu.org/philosophy/free-sw.html](http://gnu.org/philosophy/free-sw.html)
- > [opensource.org/osd](http://opensource.org/osd)

### GET A LAWYER

For small projects needing a bit of thought before redistribution, we hope this will set you on the right road. If you're scaling up, however, please seek professional advice.



## CASE STUDY

FarmBot takes tender care of your plants – and great docs mean almost anyone can build one.

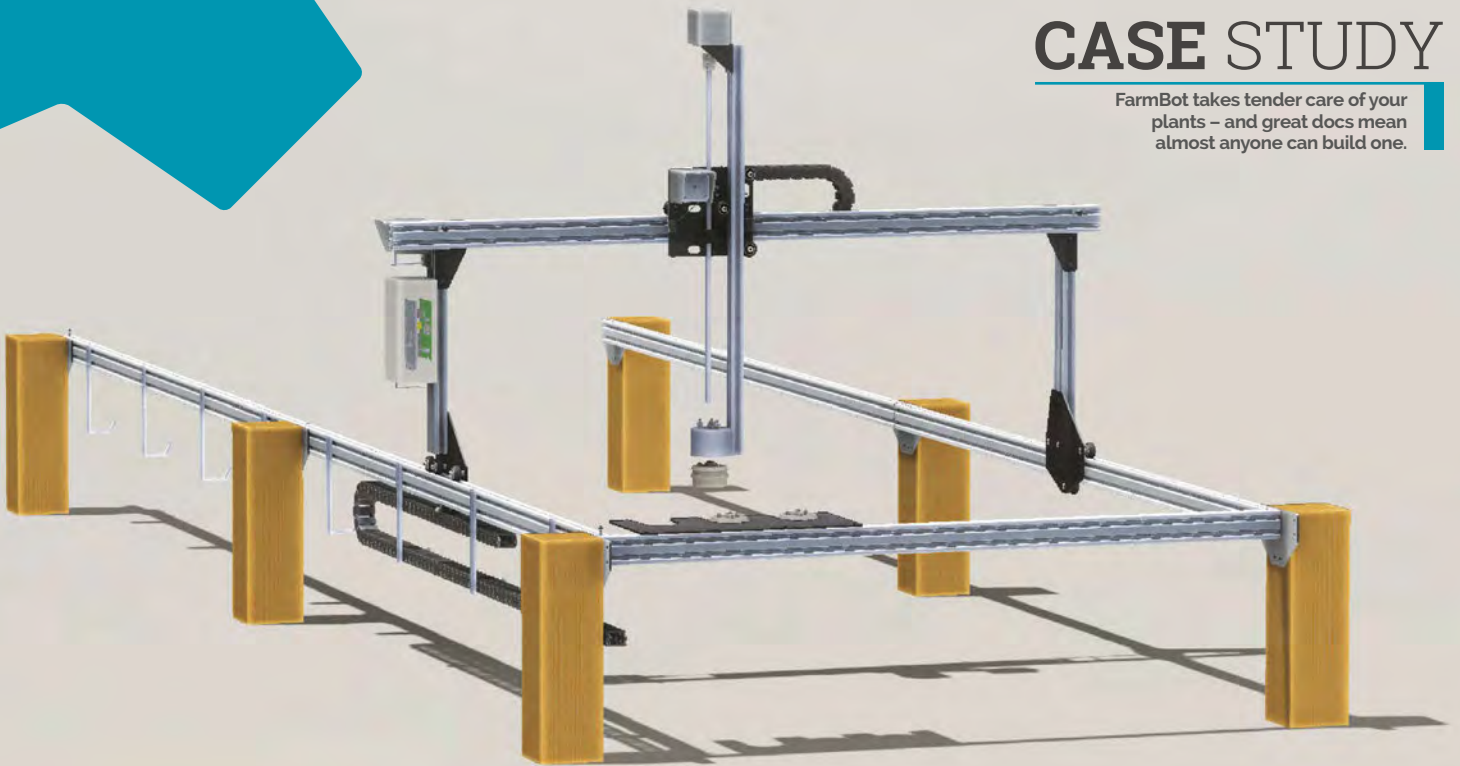

CC BY 4.0 farmbot.io

## BARLEY AND BEER – FARMBOT & BREWPI

Licence choice is in part governed by what you want end users to do with your project – and if you want them to be able to do just about anything, we have mentioned permissive licences in the main text already. To get the best take-up of your project, however, lots of great documentation is important.

FarmBot ([farmbot.io](http://farmbot.io)) is an "open-source CNC farming machine and software package built for small scale, hyper-local, DIY food

“Manage the growing of plants over a one to 20 square metre area

production,” controlled by an internet-connected Raspberry Pi 2 and Arduino/RAMPS (RepRap Arduino Mega Pololu Shield – popular for controlling 3D printers). As well as being a great project – using a CNC’s XYZ motion, combined with specialist tools, to automatically manage the growing of plants over a 1 to 20 square metre area – the FarmBot project aims to be “not just open source [but] useful source.”

### Useful source

The plans are not just freely licensed, but include detailed assembly instructions, bills of low-cost and easily available materials, troubleshooting tips, past iterations, and exhaustive information on what FarmBot is all about.

The intention is to spread FarmBot and its benefits far and wide: “we’re even committed to operating our company with transparency and open company values at the forefront,” its creators say. As well as publishing all of the designs and software under free and open licences, FarmBot maintains a busy user forum with very good guidelines to help keep things civil.

### Contributing beer

BrewPi ([brewpi.com](http://brewpi.com)), another Raspberry Pi/Arduino hybrid, controls temperature in the brewing of beer (or fermentation of wine). A popular project, it’s used by many suppliers of homebrew equipment, and to avoid potential problems, BrewPi has adopted a Contributor License Agreement (CLA) – similar to that used in the Django project – to ensure that all code contributed to the project can continue to be used and distributed with free and open licences.

BrewPi’s documents are available in reStructuredText format in the repository, as well as online.

to the next user.' Copyleft licences like the GNU GPL have been behind the success of projects like the Linux kernel. This allows large computer companies to contribute, knowing that although they were 'giving away' part of their knowledge, it would be shared in perpetuity by the community, not taken away and used to sole advantage by a competitor.

The GNU GPL is available in various 'flavours', but changes are made with great care. GPL version 2 was the standard for many years and is still used in the Linux kernel at the heart of Raspbian, Ubuntu, and

“ The GNU GPL is available in various 'flavours' ”

many other operating systems found in everything from PVRs to supercomputers. GNU GPL v3 appeared 26 years after version 2, with changes concerning threats to software freedom, particularly in relation to software patents, hardware restrictions on software modification, and digital rights management (DRM). It also made the GPL compatible with the Apache License v2.0.

The GNU Affero GPL, or GNU AGPLv3 for short, is a version of the licence for software that is used over a computer network without being *distributed* - in other words, web apps. If you want a copyleft licence for the web-based controller software for your new Raspberry Pi project, this is a good choice. And speaking of choice, many people just want their software out there with no restriction on what happens next, and no worries about licence compatibility...

## Permissive

Permissive licences like Apache, MIT, and BSD simply say 'I'm going to let you do what you like with my program.' There is no proviso; if you want to change the program then sell it, you don't have to give your customers access to the source, or any freedom to run the software elsewhere or share it. Some people believe that this is more free, as it doesn't restrict the immediate end user at all. Many hours have been spent in debate over which is the 'better' or 'more free' type of licence. Only one thing is certain: if you write some code, it's yours, and you're free to license it in any way you please - so choose what suits you best.

One tiny but important thing to be aware of: your project may be built upon various libraries and, depending how closely they are coupled to your code,

CC-BY-SA 3.0 Thesupermat, wikimedia.org

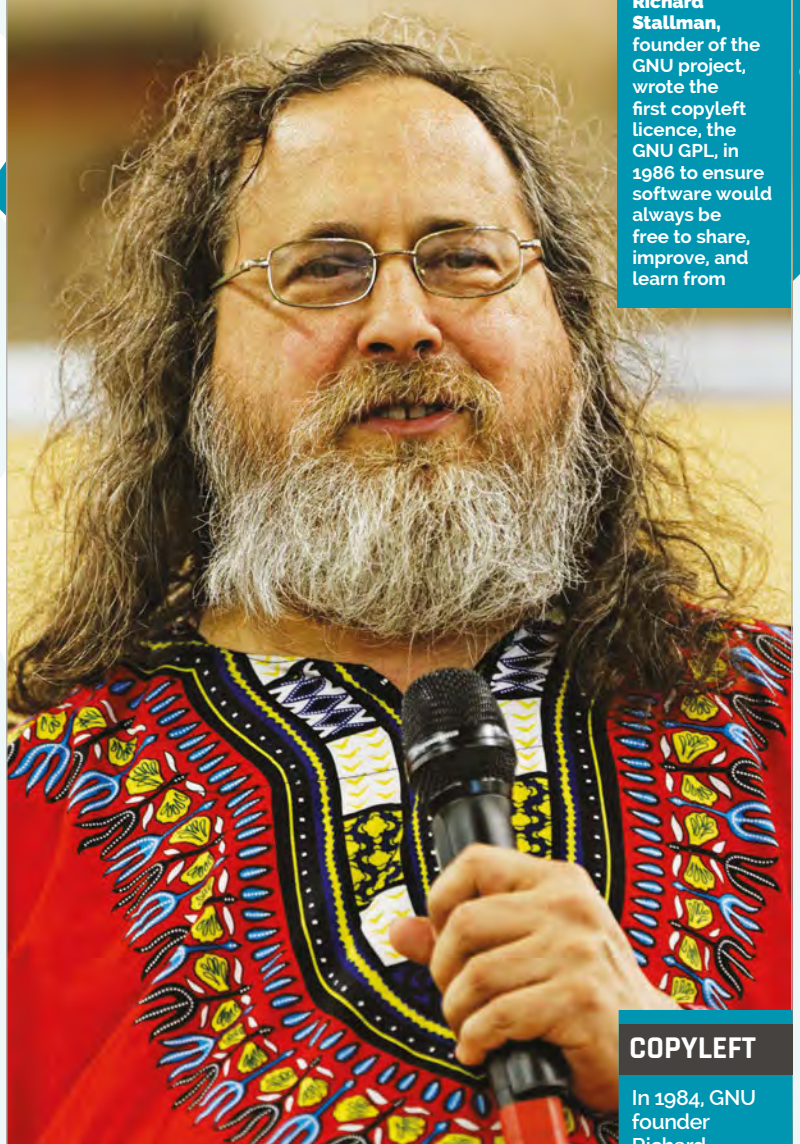

**Richard Stallman**, founder of the GNU project, wrote the first copyleft licence, the GNU GPL, in 1986 to ensure software would always be free to share, improve, and learn from

## COPYLEFT

In 1984, GNU founder Richard Stallman received a letter from fellow programmer Don Hopkins, labelled 'Copyleft - all rights reversed'. The word seemed apt for the GNU GPL, and has been used ever since.



their licences may control your choice of licence for redistribution of the whole. The Lesser GPL (LGPL) is the FSF's licence of choice for libraries, allowing dynamic linking even from proprietary (restricted) code. Naturally, permissively licensed libraries can be linked and redistributed much more freely.

The Apache licence is about the best choice in permissive licences, as it offers some protection against vexatious patent litigation - a subject needing a separate article of its own. As incompatibility between licences is a real problem when trying to combine and redistribute software from different sources, Apache 2.0's compatibility with GPLv3 - and its patent clause - make it a good choice. The Apache License is also the preferred choice of the Python Software Foundation, for those whose code will be making its way into Python's core libraries or the language itself.



**Right**  
Traditional hardware was too expensive to consider like FOSS, but with self-replicating printers (and cover-mounted computers!) hardware can be effectively free and open

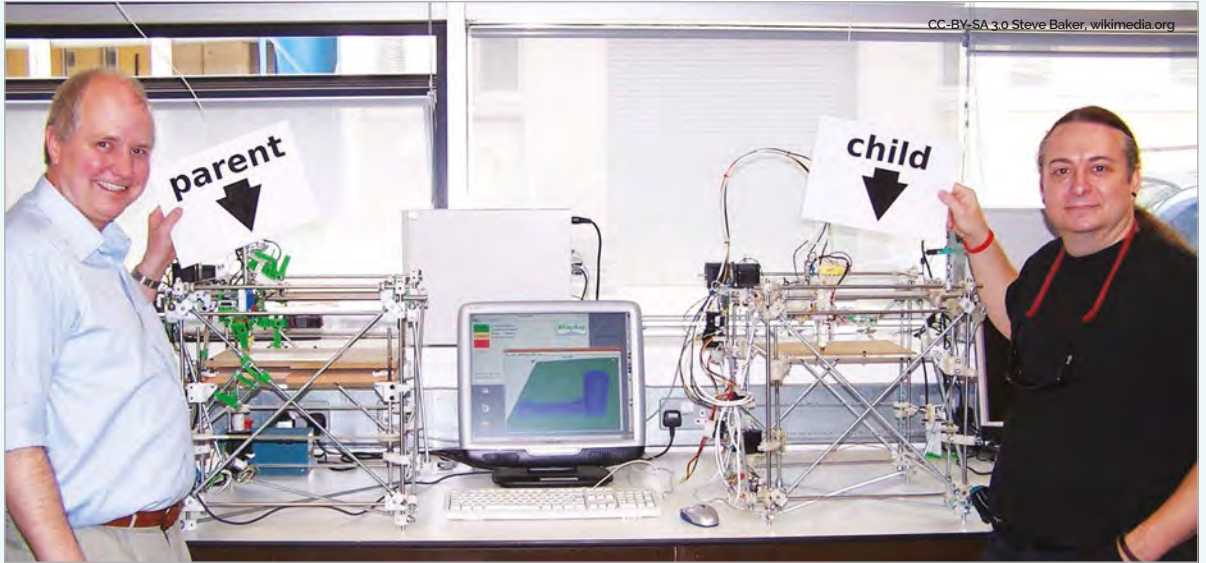

CC-BY-SA 3.0 Steve Baker, wikimedia.org



open source hardware

### Hardware, hard to license

We had a decade or two where, permissive vs. copyleft flame wars aside, things were relatively simple. Then along came the Internet of Things (IoT), cheap single-board computers, hobbyist projects, and side projects-turned-successful businesses; in other words, hardware arrived to muddy the licensing waters. Software is copyable at close to zero cost, and easily distributable around the world in seconds. Hardware needs to be fabricated, contains chips which may have their own licence terms, and comes with extra complications like firmware and proprietary codecs (such as the MPEG2 hardware decoder on the Pi). OpenCores, the community of open chip designers, distribute most of their designs as Verilog source files, licensed under the GNU LGPL.

Fortunately, for the average Raspberry Pi project, most are distributed as plans, simplifying licence considerations and leaving you free to spend time on getting the documentation right for the end users. Nevertheless, there are two hardware licences worth taking a look at. The TAPR Open Hardware License ([tapr.org/ohl.html](http://tapr.org/ohl.html)) was the first hardware-specific open-source licence, and came out of the amateur radio community. It references the GNU GPL, and differs in the crucial matter of tracking changes to original documentation. It also takes account of patents. The CERN Open Hardware License ([magpi.cc/1QvYQmY](http://magpi.cc/1QvYQmY)), developed for CERN's Open Hardware Repository, discusses 'manufacture and distribution of Products' and is popular with designers of open semiconductors. The difficulty is that although plans, instructions, and bills of parts are copyrightable as published works, copyright does not apply to the physical design and ideas that they contain. Legislation has yet to catch up with quick prototyping, additive manufacture (3D printing), and an open-source ethos in hardware. You should also consider the Solderpad License – Andrew Katz's hardware-friendly re-rendering of Apache License v2.0.

It's worth a quick read of the Open Source Hardware (OSHW) Definition 1.0 ([oshwa.org/definition](http://oshwa.org/definition)), again based upon Bruce Perens's Debian Free Software Guidelines, covering rights to 'study, modify, distribute, make, and sell the design or hardware based on that design', and other documentation on the OSHWA (Open Source Hardware Association) website. The OSHW Definition calls for documentation to be released with the hardware, for much the same reasons that source code needs to be distributed to make software freely modifiable.

The OpenROV developers CC-licensed their design, instructions, and parts list, to democratise underwater exploration



CC-BY-SA 3.0 Xeopesca, wikimedia.org

While open hardware has to cover everything from free and open 3D graphics chipsets to designs for laser-etched control panels, one thing they all have in common is the intention of the creator to share. And however dubious the current state of legislation around hardware, and thus the efficacy of the licences, adopting one of the two referenced above clearly sets out your intention for derivative works, based upon your designs, to be made and shared: a commitment to the open hardware community. This is more important than the narrower considerations of copyleft vs permissive.

## Documentation

Documentation is at the heart of any hardware project. One model is Creative Commons, devised to allow sharing of creative content, from photographs, through songs, to course materials. Wikipedia is dual-licensed under the Creative Commons Attribution-ShareAlike License – the share-alike clause being the copyleft part – and the GNU Free Documentation License (GFDL). Permissive versions are available, and CC’s ‘some rights reserved’ range of licences also extends to less free options, like those forbidding commercial use. This restriction is a real problem for social enterprises,

“ Documentation is at the heart of any hardware project ”

occasionally profitable side projects, and anything else that is ambiguously commercial. CC is also used for the millions of Scratch projects shared on MIT’s Scratch website – specifically, the Creative Commons Attribution-ShareAlike 2.0 (CC-BY-SA) licence. CC-BY-SA is also used for the design (CAD) files of the Arduino board.

Documentation for a software project, in the early days of FOSS, was often redistributed under the same licence as the code. The problem is that although you want people to take your code and run with it – or, at least, you don’t object to them doing that, which is why you’re looking at open-source licensing – documentation should ideally have a certain stability. For example, you may have a wiring diagram in your docs which, if changed, could wreck some delicate electronics. The Free Software Foundation’s GNU Free Document License (FDL) requires changes to be logged, much like the TAPR Open Hardware License.

As for the Raspberry Pi itself, despite the complexities of the various chips and their licences

## DOCUMENT FORMAT

Licensing your documentation enables it to be distributed, but spare a thought for how it will be read. PDFs aren’t a *bad* choice as such, although they can be a pain on low-resolution screens. Plain text is responsive, flowing to fit any screen, but you have no control over appearance, and diagrams and images are a problem.

The ideal solution would be to make available both online (HTML) documentation and downloadable (PDF) docs, but also source files to enable users to modify them and generate fresh documentation. TeX or LaTeX are still reasonably popular in parts of the tech community, but for the widest possible adoption and the ability to modify and improve the docs by interested users, Markdown is probably the best choice.

With a shared repository for your documentation, perhaps using Git to allow easy branching, a tool like Pandoc which converts ably from Markdown or LaTeX to PDF, HTML, and other formats, and/or one of the great Markdown or reStructuredText (RST) format to HTML static blog producers like Pelican (the Python answer to the popular Jekyll), you can simplify and automate much of the work involved in managing the documentation, without the complexity (and pain) of conventional document publishing systems.

and codecs in different versions, it’s a form of ‘ask nicely ware’. That is, back in 2012, in response to the successful beginnings of a Raspberry Pi ecosystem, the Foundation asked nicely if anyone was making a device requiring a Pi to work: “All we ask is that you include the words ‘Powered by Raspberry Pi’ somewhere on your packaging.”

If all this decision-making seems a bit much when all you want to do is share your idea, think on this. Your act of sharing has the potential to reach millions of people. People in other countries, and other situations, who may take an element or two from your project and do something with it that you never even imagined. Surely all that potential deserves just a little of your time to make sure the licences are right, so you don’t stand in the way of someone else’s creativity?

## COPYRIGHT

Copyright happens automatically upon publication. Open-source software licences give people *permission* to copy, as long as they follow the licence terms – otherwise copyright prevents that copying.

**Maker Says**

Very cost-effective multimeter with analogue bar Proster

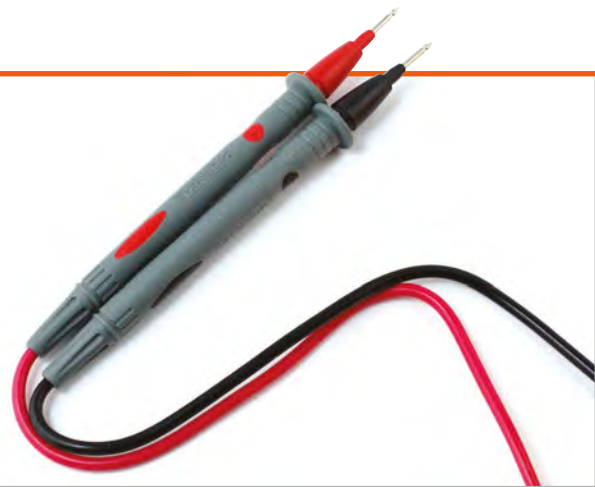

# PROSTER VC99 MULTIMETER

With everything a hobbyist could ask for, is the VC family of multimeters the bargain it appears to be?

**Related**

**EXTECH EX330 MULTIMETER**

The EX330 has all the features of the Proster VC99, swapping only the transistor test mode for non-contact AC voltage detection, in a more compact package. Sadly, it's also considerably more expensive.



£47 / \$60

adafruit.com

**F**or years there was a gulf between affordable multimeters for the hobbyist and professional-grade hardware. Outgrowing a £10 multimeter from a high-street electronics shop typically meant jumping to £100 or more for a pro device. More recently, though, Chinese multimeters have begun to give the big boys a serious run for their money without breaking the bank – devices like the Proster VC99.

Part of the VC family and available from its original design manufacturer (ODM) under different brands, the Proster VC99 is designed to give the hobbyist a wider range of functionality than your average pocket multimeter. The usual features are, of course, present and correct – there's AC voltage sensing up to 1,000V and DC up to 700V, current measurement

up to 20A for a maximum of ten seconds, capacitance measurement, and resistance measurement with visual and audible continuity test modes. But the VC99 really packs out the extras list: there's a frequency counter mode suitable for measuring up to 60MHz with a  $\pm 0.5\%$  accuracy, a temperature sensing mode with bundled K-type temperature probe, and a current gain test (hFE) for PNP and NPN transistors through a built-in multi-pole socket. For anyone who has ever bought a multimeter with an hFE mode plug-in adapter, only to lose said adapter shortly after purchase, that feature alone is worth the asking price.

**Paying for quality**

Naturally, there are reasons why the Proster VC99 doesn't cost twice the price. Chief among these is its accuracy: while the base accuracy

of  $\pm 0.5\%$  compares well with even expensive multimeters, the  $\pm 3.5\%$  accuracy rating for capacitance measurement is decidedly less impressive. The screen, while large and easy to read in most conditions, is not back-lit, and the kickstand to the rear of the chassis is only capable of holding the multimeter at one rather shallow angle.

Surprisingly, the VC99 doesn't cut every corner. Included with the multimeter is a handy zipped storage bag, while the anti-shock rubber around the outside of the chassis includes storage mounts for the probes. These are worth mentioning, too: compared to similarly priced rivals, the probes included with the VC99 are of a surprisingly high quality. Unless you need something specific, like probes ending in test hooks, you're unlikely to be looking to upgrade any time soon.

amazon.co.uk

£25 / \$28



## Essential features

When setting the VC99 up for measurement, it's easy to forget that it's a budget multimeter. The probes sit securely in their ports, and the mode dial switches with a pleasingly tactile click. Buttons are included just below the display for various functions, including the ability to switch between frequency and duty cycle measurement - handy for testing Pi projects which use software-driven pulse-width modulation - and for enabling recording of maximum and minimum readings. There's also a button to enable relative measurements to be taken: when measuring resistance, for example, this can be used to automatically subtract the resistance of the test probes themselves from the displayed figure.

What you don't get for the low purchase price is any sign of a

calibration certificate. While the measurements on our test unit proved accurate against calibrated hardware, there's no guarantee the next model off the production line will be as well-calibrated. It's possible to remove the casing from the multimeter and calibrate manually by adjusting on-board potentiometers, should you have access to calibrated hardware against which to compare measurements, but doing so will invalidate any warranty you may have had.

## A tough read

The only other bone of contention with the Proster VC99 is the bundled manual. Small and confusingly written, it provides most of the information you could need to get the best from the device, but not in the most accessible manner. Signs of poor translation are also

present, including on the face of the multimeter where its ability to power off automatically after 15 minutes of inactivity is proudly emblazoned as 'AUTO OFF POWER'.

These are minor niggles. While not every hobbyist will need anything more feature-packed than your average pocket multimeter, those who do will find the VC99 more than up to the job. Anyone working in an ill-lit environment, though, would do well to spend any money saved on a lamp to make up for the lack of illumination on the multimeter's display.

## Last word

While its accuracy is definitely more suited to the hobbyist than the professional, the Proster VC99 multimeter offers a wealth of functionality at a pocket-friendly price.



Maker Says

The ultimate protection for your new little friend!  
C4 Labs

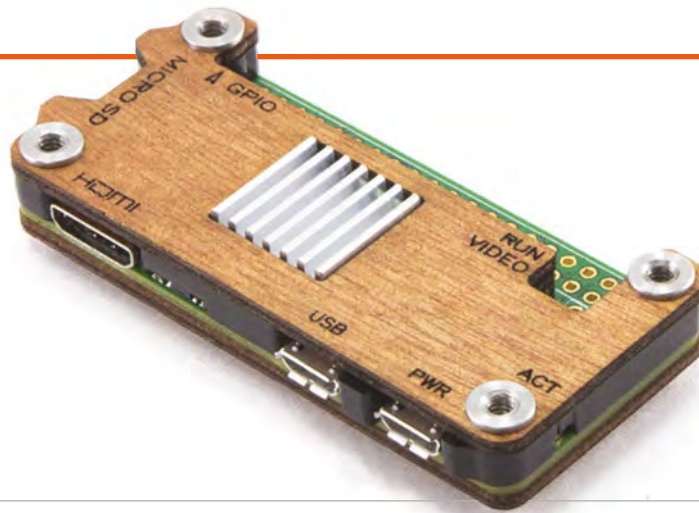

# ZEBRA ZERO CASE

A case for the Raspberry Pi Zero that you can also get with a wooden finish. Is it practical or more for the aesthetics?

Cases for the Raspberry Pi Zero have been fairly quick to market: by the time *The MagPi* issue 41 was released, there was already at least one to get your hands on, and more have been popping up since. This may be because of the popularity of the laser-cut acrylic sheets that Pimoroni has promoted – either way, it has created a small market of cases made with a more interesting material: wood.

One of the first of these was C4 Labs with its Zebra Zero case. It comes in both a wood-finish version and a normal clear acrylic one, so you have your choice of style. However, even the wood-finish case isn't fully wooden: a pair of ABS-plastic spacers separate the two wooden plates at either end. This is much more cost-effective while still achieving

the overall effect. The wood is also laser-cut, so it's nice and smooth. Each important port is uncovered and labelled via etching into the wood panel. It's simple, neat, and it works well. The GPIO is completely uncovered, which, while making the Pi Zero seem a little naked at first, does make a lot more sense when a GPIO header is soldered on. Unfortunately, there don't seem to be any Pi Zero cases that cover up this part of the board, and while there are definitely arguments for having it open, the option to have it closed off if needed would be nice.

Like the wooden case, the acrylic one has the same etchings, precision cuts, and smoothness. Both are supplied with very sturdy screws that interlock over each other, rather than a nut and bolt. These same holes grab the Pi Zero as well, so they could be

used for mounting purposes with the right equipment.

Both versions of the case are great and sturdy. The heatsink seems a little like overkill, but it's a nice little touch and it looks good aesthetically with the wooden case. If you really like the Zebra Zero case, there's also a much larger one available that incorporates a breadboard, perfect for prototyping.

Last word

A great case with a fairly unusual look. It allows for full access to the ports on the Pi Zero – although if you're not using the GPIO, it makes it seem a little exposed.



Related

NUCLEUS ZERO CASE

Another wooden case: this one has more wooden layers and a more abstract design. It also covers the GPIO pins.



£5 / \$7

magpi.cc/1KWsfAF



pimoroni.com

£12 / \$15

**Maker Says**

A super affordable high-quality DAC for the Raspberry Pi  
Pimoroni

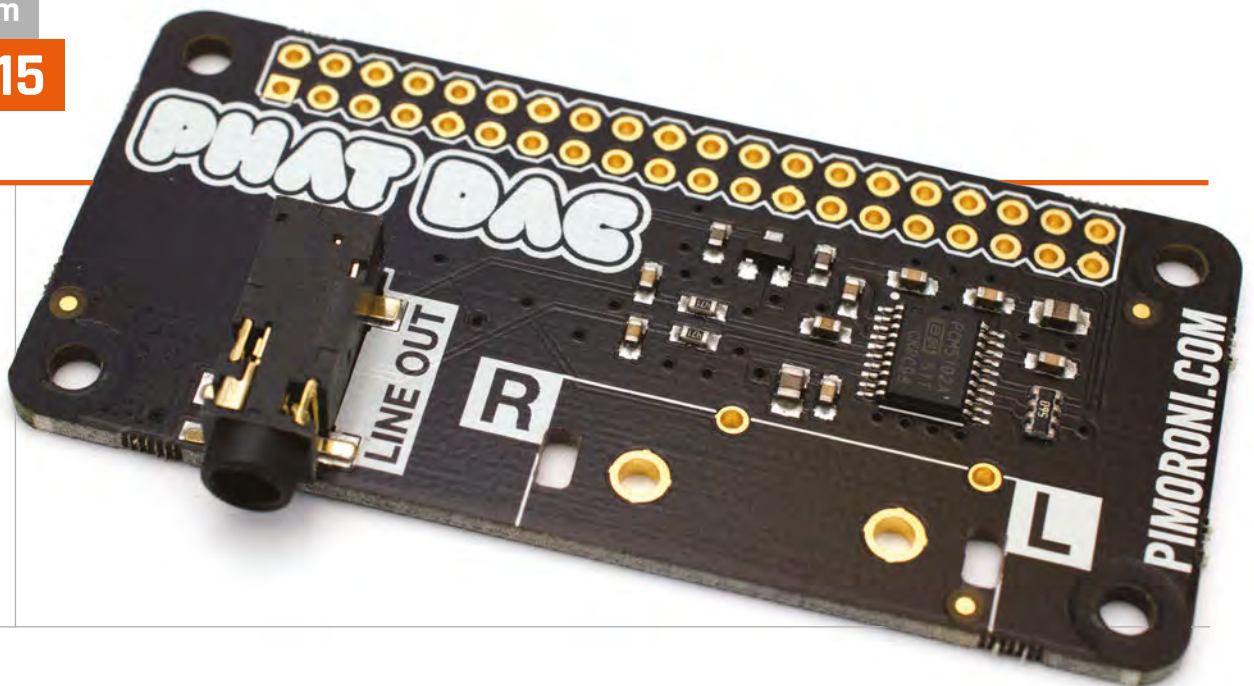

# PIMORONI PHAT DAC

If you're disappointed by the Pi Zero's lack of analogue audio output, the pHAT DAC may be just the add-on you need

**T**he Pi Zero's minuscule dimensions make it well-suited to a variety of tasks, except for one omission from its feature list: analogue audio. For anyone trying to embed a Pi Zero into an old radio or speaker system, that's a loss too far. Fortunately, the clever people at Pimoroni have a solution in the form of the pHAT DAC.

Part of the pHAT family – a range of Hardware Attached on Top (HAT) boards built with the Pi Zero form factor in mind – the pHAT DAC adds a high-quality digital-to-analogue converter (DAC) to the board, allowing any Pi Zero to output line-level audio, ready for external amplification.

The output of the pHAT DAC shouldn't be confused with that of the analogue output of the full-size Raspberry Pi family, either: the pHAT's Texas Instruments PCM5102A DAC is a cut above, offering noise-free 192kHz 24-bit line-level audio.

The pHAT DAC is supplied with a 40-pin female header which needs to be soldered onto the board before it can be connected to the Pi Zero, to which you'll need to have soldered a 40-pin male header. There's method in Pimoroni's madness here: if you're building a permanent project, you can drop the female header and solder the pHAT DAC directly to the Pi Zero's pins to create an ultra-thin circuit board sandwich. You can also add a pair of RCA connectors, available separately for £1.50, to complement the 3.5mm jack.

With the soldering out of the way, installation isn't as straightforward as it could be. Step-by-step instructions are provided, but are unsuitable for the latest Raspbian release – and while a community member has stepped up and provided an installation script to make things easier, this isn't yet linked from the product page.

There's another fly in the ointment once installation is

complete: there's no easy way to switch between the pHAT DAC and HDMI outputs. For most uses this isn't a problem, but if you were planning to turn a Zero into a multi-function portable music player, it may cause a headache.

When you're up and running, there's plenty to like about the pHAT, though – in particular, the superb audio quality when paired with a good-quality amplifier and decent set of speakers.

**Last word**

While the installation experience needs work, the pHAT DAC certainly fills a hole. If you need analogue audio from your Pi Zero, it can't be beaten – but paying three times the cost of the Zero itself may sting a little.

**Related****HIFIBERRY DAC+ STANDARD RCA**

The HiFiBerry uses top-quality components and has RCA jacks pre-soldered, but its size makes it less suitable for Pi Zero use.



£23 / \$40

hifiberry.com

£18/\$30

**Maker Says**

Turn your Raspberry Pi into a robot controller!  
**MonkMakes**

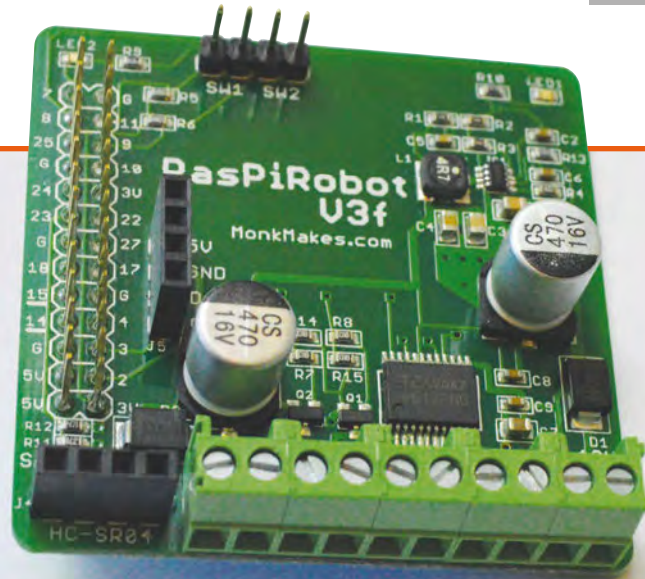

# RASPIROBOT V3 BOARD

Get a head start in making a Raspberry Pi robot with this board: it handles all the basics you need

**I**f you've ever made a Raspberry Pi robot, you'll know there are some basic essentials to bear in mind: running the motors of your automaton via the Raspberry Pi, and the ability to power the Pi and motors independently without using a trailing power cord. Then there are other, less-necessary bits such as wiring the robot up properly, and the ability to add sensors. These are still important and something you'd have to learn, but there are different layers to cover.

There are some products that try to encompass it all, and RasPiRobot is one of these. It's a HAT (a board that attaches on top of the Raspberry Pi) offering access to two motor controllers, and will also power the Pi from a battery pack attached to it. This covers several of the issues faced when creating a

robot; add I<sup>2</sup>C and ultrasonic sensor connectors on top of this, as well as full access to the GPIO pins the board covers, and you have quite the complete package.

The board is nice and compact, fitting neatly on top of the standard Raspberry Pi B+/2/3 form-factor, and is even smaller than the A+. The board only requires the first 26 GPIO pins, making it functional on the original Model A and B too, in case you have one lying around waiting to be used for something. Everything comes pre-soldered and, honestly, for the price it's a bit of a steal. Even if it may be slightly more targeted towards novices, it leaves plenty of room to grow.

The board comes with its own Python library, with plenty of examples to figure out how it works. It's fairly simple, requiring

you to make sure the motors and main sensors are plugged into their intended slots, and you can definitely program any robot you create with it very efficiently.

RasPiRobot V3 does what it sets out to do well, at a very good price. If you're looking to start out in Pi robotics or want to take a step beyond beginners' kits, you could do a lot worse than this board.

**Last word**

An easy-to-use kit that offers a lot of functionality for Raspberry Pi robot makers, with very little fuss or hassle. It's also very cheap for what you get, making custom robots a more attractive and affordable prospect.



**Related**

**ULTRABORG**

A different yet still very competent way to add motorboard and robot control to the Raspberry Pi. You can get it in many different kit versions.



£16 / £23

magpi.cc/1RJeWC

modmypi.com

£34 / \$49

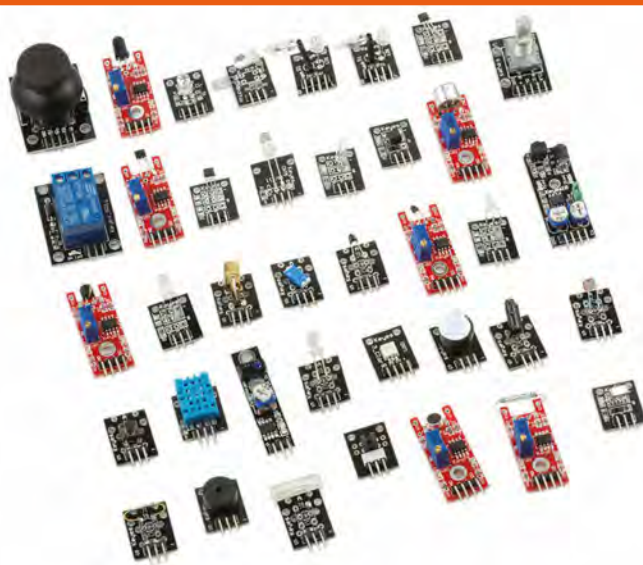

## Maker Says

💡 Adds an enormous amount of variety and additional fun to every maker's toolbox  
ModMyPi

# KEYES 34-PIECE SENSOR EXPERIMENT KIT

A box of tricks to play and learn with, but does it make sense to buy them like this?

**F**or those making their first foray into the world of electronics, there's a bewildering array of components to choose from. So a kit like this one can be a useful starting point. While it's listed in the Arduino section of the ModMyPi site, and although it is labelled 'for Arduino' on the box, it will work with most microcontrollers, including the Raspberry Pi. The kit isn't supplied with a breadboard or any other components, so you'll need to source those separately.

You get a fairly wide range of sensors for your money, working out at £1 each. By our rough calculations, the combined cost of the components would come to at least £40 (plus any shipping), so it represents reasonable value. In addition, each part comes in its own ziplock bag, safely stowed in one of the compartments in the

sturdy case. The only documentation supplied is a single sheet identifying each sensor, in English and Chinese, and some have misleading names. Fortunately, the ModMyPi site offers several handy links to find out more about the sensors and how to use them, including Python and C code examples, along with a Raspberry Pi-based lesson plan.

One thing to note is that while this is described as a 'sensor' kit, its contents also feature a selection of switches, microphones, and LEDs. These are of varying usefulness. There's some overlapping of functionality, too, with three different temperature sensors and three Hall effect modules to detect magnetic fields; since they require different implementation methods, though, it's still beneficial for learning purposes.

There are quite a few fairly standard parts, such as a couple

of two-colour LEDs and buzzers. More exotic components include a flame sensor, which can detect a fire within 80cm, and a heartbeat sensor that's placed around your finger and flashes an LED with your pulse. Other parts, such as an IR line follower and an obstacle avoidance sensor, may also come in useful for robotics projects.

## Related

### CAMJAM EDUKIT 2

Far fewer sensors, but it does include everything you need – including breadboard and jumpers – to follow the excellent worksheets.



£7 / \$10

camjam.me

## Last word

The kit offers reasonable value, particularly with the compartment case included, and offers plenty of possibilities for experiments – so long as you already have some jumper wires, at least. Anyone focusing on a single project would be better off buying the required components separately.



# RASPBERRY PI BESTSELLERS FOR DUMMIES

Wiley's popular For Kids & For Dummies imprint turns out some near-genius works.

## RASPBERRY PI PROJECTS FOR DUMMIES

**Author:** Mike Cook, Jonathan Evans & Brock Craft  
**Publisher:** Wiley  
**Price:** £17.99  
**ISBN:** 978-1118766699  
[magpi.cc/1TiAVfG](http://magpi.cc/1TiAVfG)

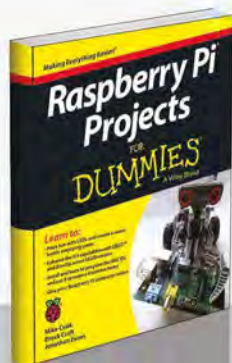

Gets you started with Pi and workshop setup, then throws you into a fun world of cool projects – raspberry jazz glitter trio! – and teaches you electronics and Python along the way.

## RASPBERRY PI FOR KIDS FOR DUMMIES

**Authors:** Richard Wentk  
**Publisher:** Wiley  
**Price:** £21.99  
**ISBN:** 978-1119049517  
[magpi.cc/1TiBaXZ](http://magpi.cc/1TiBaXZ)



From Scratch and Sonic Pi, via command line and nano, to Python and choosing a web server, Wentk's clear style and gentle humour make each learning challenge approachable.

## PYTHON FOR KIDS FOR DUMMIES

**Authors:** Brendan Scott  
**Publisher:** Wiley  
**Price:** £21.99  
**ISBN:** 978-1119093107  
[magpi.cc/1TiBiHd](http://magpi.cc/1TiBiHd)



A great range of projects (both silly and useful) to take readers of any age from the basics, through to object-oriented programming techniques. We can even forgive the use of Python 2.7!

## THE MAKER'S GUIDE TO THE ZOMBIE APOCALYPSE

**Author:** Simon Monk  
**Publisher:** No Starch  
**Price:** £16.50  
**ISBN:** 978-1593276676  
[magpi.cc/1VgmTtW](http://magpi.cc/1VgmTtW)



Have you ever pondered how you would survive a zombie apocalypse? No? There's no need to panic: Simon Monk has given the matter extensive consideration, and the result of all his hard work is an entertaining, yet surprisingly useful collection of projects for the Raspberry Pi and Arduino. Monk says people tend to be either zombie lovers or zombie indifferent: your reviewer falls into the latter category, yet was won over by the sheer geeky genius of the whole enterprise.

The first problem faced by electronic hobbyists in the post-

apocalyptic world is a lack of electricity: solar cells are covered, but the bike-powered generator has real DIY kudos, and could be powering your maker shed well before the apocalypse arrives. Alarms, distractions, Morse code, and haptic communication are among what follows.

The Pi is used in video monitoring of zombies via USB webcam, setting up an FM transmitter beacon to communicate with other survivors, and a control centre in which it integrates with some of the Arduino projects. Beyond this are a range of simple and fun electronics circuits, and every chapter is packed with useful information on electronic theory, construction, and programming nuggets, along with tips for surviving the zombie apocalypse. It might not happen, but it would be foolish not to be prepared.

Score ★★★★★

## INTERMEDIATE C PROGRAMMING

**Author:** Yung-Hsiang Lu  
**Publisher:** CRC  
**Price:** £49.99  
**ISBN:** 978-1498711630  
[magpi.cc/1Vgnbkk](http://magpi.cc/1Vgnbkk)

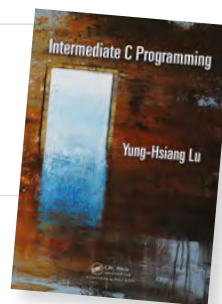

After completing your first C tutorial, you then run up against a yawning gap to cross. There are many specialist books for advanced C programmers, and plenty of code out there to read, but to make the leap from writing short programs of perhaps 20 lines of C, to a couple of thousand lines of code, you need Lu's help to learn some essential concepts.

There is enough information here to pull confident beginners through (supplemented, perhaps, with a basic online tutorial). This isn't structured like a typical beginner's tutorial, however, and

it (usefully) gives a lot of useful coverage to low-level interactions between your code and the hardware: early treatment of the stack, for example, is recalled a couple of chapters later, when looking at pointers and call-by-value.

Combining maths and programming, Lu also uses the full GNU/Linux suite of C tools. Testing and debugging are both emphasised – including use of Valgrind to check for memory errors – and both from a lot earlier on than is customary in other works, for which full marks to Lu. But the author emphasises that “no tool can replace a clear mind”, and endeavours to give you the skills and mindset to code correctly in C.

Score ★★★★★

# NUMERICAL PYTHON

**Author:** Robert Johansson  
**Publisher:** Apress  
**Price:** £35.50  
**ISBN:** 978-1484205549  
[magpi.cc/1PWNUtE](http://magpi.cc/1PWNUtE)

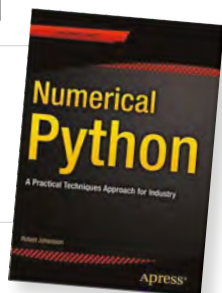

Python's numerical and mathematical modules aren't just appreciated by coders working in the sciences: the PSL, NumPy, matplotlib, et al. are also very useful in business management, financial engineering, big data, and even cloud computing. It is for these fields that Johansson has written this detailed guide.

After a good introduction on IPython with its notebook feature, Spyder is suggested as an IDE apt for numerical Python work. Some essentials for numerical computing (vectors, matrices, and multidimensional arrays) follow, to ease the reader into NumPy;

then SimPy to use analytical and symbolic methods on problems. Visualisation with matplotlib

further these foundations. Building on these fundamentals, the following chapters survey the domains of applied mathematics and computational science, solving problems, and using some of the best of Python's diverse packages. Working through everything from linear equation solving, through sparse matrices, to Bayesian statistics, Johansson helps you brush up on problem solving, mathematics, algorithms, data, and even serialisation.

IPython notebooks containing the source code listings for each chapter can be downloaded from Apress or Johansson's GitHub pages. The book is a valuable reference across many fields.

Score ★★★★★

# LEARNING ELIXIR

**Author:** Kenny Ballou  
**Publisher:** Packt  
**Price:** £22.99  
**ISBN:** 978-1785881749  
[magpi.cc/1PWPbd4](http://magpi.cc/1PWPbd4)



If you're looking to try functional programming to build more resilient apps, then Elixir with its Ruby-inspired syntax is a good choice. Ballou eases the reader in with Elixir types, such as atoms, and other features like lazy evaluation of ranges. Very gently, a lot of what seems strange in a quick glance at Elixir and Erlang, is made familiar, or at least intriguing. Pattern matching and the map function round off chapter 2, preparing you to work with modules and functions.

Ballou skilfully builds on ideas presented earlier, combining

pattern matching, first class functions, and features of the Erlang VM to build your understanding of Elixir, before introducing more advanced features and getting started on functional algorithms. Tail recursion and sorting algorithms highlight the efficiency of Elixir.

More data structures and pattern matching lead onto flow-based programming, or stream processing. All this without control statements, as branching is introduced late – functional algorithms make it less necessary – in a short chapter which also (finally) brings in testing. Ballou rounds off with other necessities for full use of Elixir: concurrency, the OTP framework, and metaprogramming. Learning Elixir is concise, useful, interesting – like the language itself.

Score ★★★★★

# ESSENTIAL READING: CLOJURE ESSENTIALS

Learn the greatness of immutable data, concurrency, pure functions, and metaprogramming with these essential recent releases.

## Clojure for the Brave and True

**Author:** Daniel Higginbotham  
**Publisher:** No Starch  
**Price:** £23.50  
**ISBN:** 978-1593275914  
[nostarch.com/clojure](http://nostarch.com/clojure)

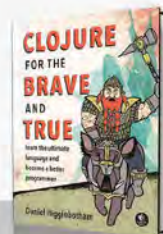

Not an in-depth study, but a practical and fun way of getting started with Clojure and functional programming.

## Clojure Applied

**Author:** Ben Vandgrift & Alex Miller  
**Publisher:** Pragmatic Bookshelf  
**Price:** £25.50  
**ISBN:** 978-1680500745  
[magpi.cc/1PWPpy7p](http://magpi.cc/1PWPpy7p)



Move from the basics, to using immutable data structures and first class functions in real code for real work.

## Clojure in Action

**Author:** Amit Rathore & Francis Avila  
**Publisher:** Manning  
**Price:** £35.31  
**ISBN:** 978-1617291524  
[magpi.cc/1PWPCUI](http://magpi.cc/1PWPCUI)



Expanded and updated for Clojure 1.6, with ClojureScript, and fewer Java-based assumptions – ideal for Pythonistas and Rubysts.

## Clojure for Data Science

**Author:** Henry Garner  
**Publisher:** Packt  
**Price:** £28.99  
**ISBN:** 978-1784397180  
[magpi.cc/1PWR4qb](http://magpi.cc/1PWR4qb)

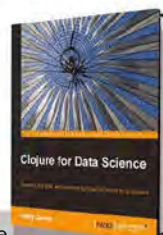

Garner will improve your practical Clojure skills whilst giving you a thorough and comprehensive grounding in handling data.

## Clojure Recipes

**Author:** Julian Gamble  
**Publisher:** Addison Wesley  
**Price:** £24.99  
**ISBN:** 978-0321927736  
[clojurerecipes.net](http://clojurerecipes.net)



Build on your Clojure knowledge to gain real-world skills with DSLs, Storm, Datomic, and ClojureScript.

# THE MONTH IN RASPBERRY PI

Everything else that happened this month in the world of Raspberry Pi

## PERFORM YOUR OWN EXPERIMENTS WITH SENSE HAT

**W**ith the Astro Pis now switched on, schoolkids' code is being used in low-Earth orbit to test out new and amazing things. Powering the Astro Pi is nothing more than a Sense HAT and a camera module attached to a Raspberry Pi: parts that are easily obtainable. You can also perform your own experiments with them, and we have a few you can check out in our book, *Experiment with the Sense HAT*, available as an e-book and now also in print. Here are some of the amazing tutorials you can find in it. For more details on where to get it, visit: [magpi.cc/Sense-HAT-book](http://magpi.cc/Sense-HAT-book).



### DIGITAL MAGIC 8-BALL

Use the Sense HAT's motion sensors to create a fully functional magic 8-ball and experiment with the accuracy of a random number generator as it tries to predict the future. This project teaches you about the various motion sensors and gyros on the Sense HAT, as well as giving you some tips on how to use the LED matrix to display text and messages. It's all programmed in Python 3, so it also teaches you more about how to use the popular language. Maybe you could modify the code and create your own version?



### SENSE HAT DATA LOGGER

If you want to make the most of all the various sensors and gizmos on the Sense HAT, the data logger allows you create a record of all the HAT's different readings: temperature, pressure, humidity, motion, tilt, etc. It's programmed in Python and also gives you some tips on how to read the data properly. From here you can create graphs and charts to display the changing conditions of your bedroom, kitchen, or garage. You could use the data to figure out when it's coldest, when people may have entered, or anything else you can think of.



### ASTRONAUT REACTION GAME

This game is very similar to one Tim Peake and the rest of the crew of the International Space Station are using on the Astro Pi. This one is coded in Scratch, though, to make it more gamey, and it allows you to test your reaction times. There are even some special graphics you can use in it where Tim Peake himself will show up! This one is less an experiment on your surroundings and more of an experiment on yourself and friends: can you train yourself to get faster?

# CROWDFUND THIS!

The best crowdfunding hits this month for you to check out...

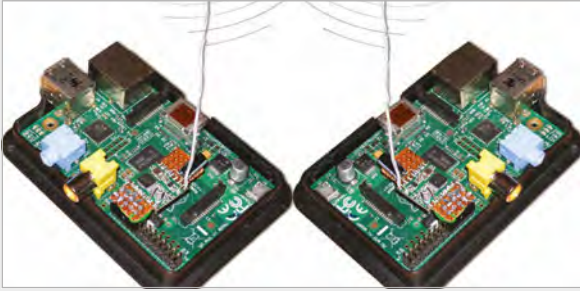

## PI433 - RADIO MODULE

[kck.st/20uoaAY](http://kck.st/20uoaAY)

While the new Raspberry Pi 3 now has a built-in wireless internet connection, that's not quite the same as a radio transmitter and receiver. This crowdfunding project is for a 433MHz radio module, hence the name, and allows for communication to the Pi over that frequency, between two Pis on it, and with anything else that operates over 433MHz as well. It should be nearing completion by the time this issue comes out, so give it a look if you're interested in another wireless way to use your Raspberry Pi.



## PIJACK - ETHERNET FOR PI ZERO

[kck.st/1Q7yE1U](http://kck.st/1Q7yE1U)

Much like the Model A and A+, the Raspberry Pi Zero lacks an Ethernet port. The Zero forgoes it for the sake of keeping its size down, and you can add an Ethernet connection via USB if you wish to do so. There is a new solution trying to get crowdfunding, though: the PiJack is a HAT for the Pi Zero which adds a 10Mbps Ethernet port. It's only 10Mbps to keep costs down, making it suitable for something like the Pi Zero. It will then easily integrate into Raspbian as well.

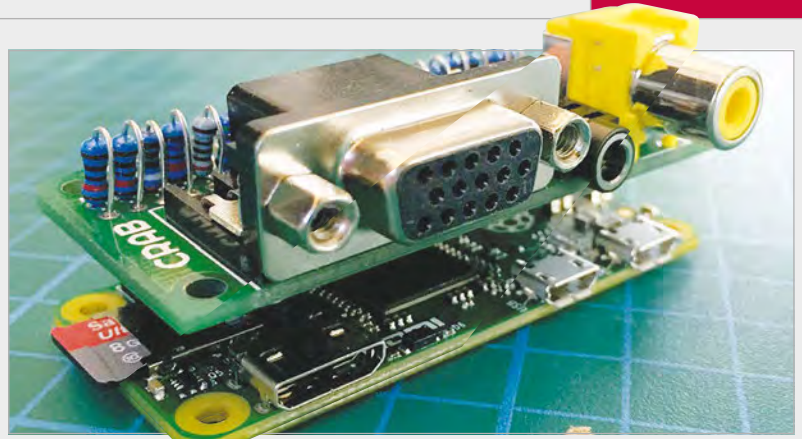

## ANALOG EXPANDER CAP

[kck.st/1RynV6o](http://kck.st/1RynV6o)

Much like the reason the Raspberry Pi Zero doesn't have an Ethernet port, there are no analog audio- and video-out ports in order to save space. Ben has created a HAT for the Raspberry Pi Zero that fits over the GPIO pins and adds VGA, composite video, and audio-out ports. The PCB it sits on neatly fits the dimensions of the Pi Zero, just about squeezing the three ports on top of it. It has already been funded, so you should hopefully be able to get your hands on one even if you miss the campaign.

## BEST OF THE REST

Here are some other great projects we saw this month

### SMOKEYPI

[magpi.cc/1R6WFZW](http://magpi.cc/1R6WFZW)



Mitesh Patel got our mouths watering by showing us some perfectly cooked burgers that he'd made using a Pi-powered sous-vide machine. It's hardly a new idea, but we really love when people come up with new ways of doing it. Check out his GitHub repo via the link to learn how to make one for perfect steaks.

### TABLET CLOCK

[imgur.com/xdlcX3p](http://imgur.com/xdlcX3p)

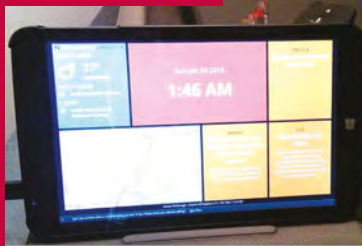

Reddit user hunterk11's clock broke on him one day. So instead of getting a new one, he had a Raspberry Pi run Dashing, which was then displayed on the web browser of a spare tablet. He instantly had a more useful clock with much more information than you'd get from other shop-bought alarm clocks.

# HOUNDIFY ADD VOICE CONTROL TO YOUR PROJECTS

SoundHound's speech-to-meaning engine enables better voice control and customisation. Its creators think it could revolutionise your Pi projects...

**“W**e started working on this project more than nine years ago; we had this vision that one day you're going to talk to all the technology around you,” Keyvan Mohajer, CEO of SoundHound, tells us. SoundHound is a popular audio recognition software for smartphones that you've probably used at some point to identify a song you can hum but don't know the name of. Today, though, we're talking to Keyvan about the recent announcement and release of Houndify.

Houndify is the next generation in voice-recognition software, beyond the likes of Google Now and Siri that are currently available on mobile devices.

“Technology like computers, cellphones, cars, fridges, your thermostat, etc. – we will be talking to them, they will be talking back to us, and we'll continue talking together,” explains Keyvan. “A conversational interface between humans and technology. We had this vision more than a decade ago and today

that seems obvious because it's happened, but I assure you that when we were sharing our vision with other people in the early days, a lot of people had doubts.”

## Three laws safe

How does Houndify work, then, and what differentiates it from other software? According to Keyvan, there are three main parts that make it different:

“The first one is what we call speech-to-meaning. What everyone else does is speech-to-text and then text-to-meaning... We saw two problems with that; one is latency or speed, so if you have to do speech-to-text then text-to-meaning, the user has to wait for that. Maybe some short queries are OK, but queries that get a little more complex and longer oftentimes you see a delay, even with Google.

“The other problem that's less obvious is accuracy. If you do speech-to-text blindly without caring about the meaning, you're more likely to make a mistake, and then you're sending that wrong text to the next step. If you think about how your own brain works as you listen to people talk, you're not doing speech-to-text in your brain – you're doing speech-to-meaning, and caring about the meaning helps you with accuracy of your analysis in your own brain. We thought that if we can

Keyvan Mohajer is the CEO of SoundHound – the company behind Hound and Houndify – which he founded in 2005





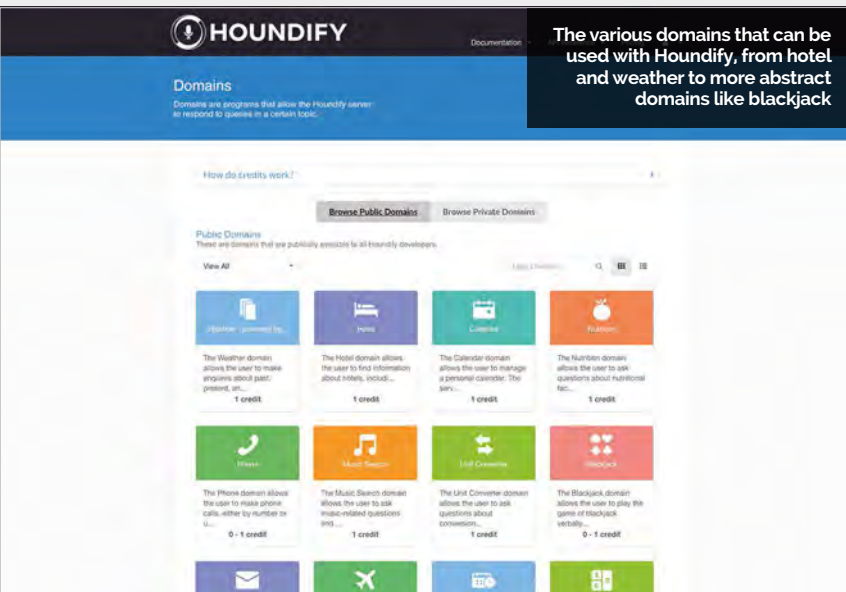

understand the meaning in real-time as we are understanding the text, we can do a better job with the accuracy also. That turned out to be true: with our benchmarks, we saw a huge improvement in accuracy.”

The second key difference is the ability for Houndify to understand complex queries, and this is the aspect that really impresses people. Users go from asking a series of short questions to asking long strings which would not be usable anywhere else. For example, the following sentence works with Houndify:

‘Show me hotels in San Francisco for tomorrow that are less than \$300 but not less than \$200, are pet friendly, have a gym and a pool, with three or four stars, staying for two nights, and don’t include anything that doesn’t have air conditioning.’

### Master of your domain

Last but not least, Houndify’s ‘domains’ are a key differentiator.

“It’s important to understand that this is not like magic,” Keyvan explains. “You can’t just make it all work with everything. If you want it to understand weather, you have to integrate it with the weather provider and understand the type of interactions that people will do with that domain. Same for if you want to understand stock markets or local business search or hotel

search. These are all domains. We call them domains because they are big but they’re very specific, so they need to be added one by one. We thought that to make this really useful, we need to be able to understand a lot of things, so we need to be able to add these domains very fast.”

Google and Apple also use such domains, but they only have a few and have not added many new ones in the past few years.

“We built a platform that allows us to add these domains faster and more efficiently than [rival services],” Keyvan tells us. “The key was that you don’t have to be a scientist in that space to be able to use the platform. You don’t need to have a PhD in linguistics or speech; we employ fresh computer science graduates, and they are able to understand our platform and add new domains within days. When we announced our platform in June of last year, we had about 50 domains; today we have more than 110 domains... Eventually we will open the domain level part of this platform to outside developers, and that’s when we go from hundreds internally to 1,000 to 10,000... 100,000... you know. 1,000,000 domains.”

Houndify is available for use in projects now for free and on Raspberry Pi. Check [houndify.com](http://houndify.com) for more information.

## HOUNDIFY WITH PI

Houndify works well on the Raspberry Pi, with enough resources to run it just fine. Keyvan tells us how it has been used:

“We sponsored a huge hackathon at the University of Pennsylvania and they had 1,300 students working over two or three days. We had a big presence there and I believe Houndify was the most used API in the whole hackathon. There’s a lot of interest by the developer community and a lot of them use the Raspberry Pi.”

In the Houndify office itself, an engineer hacked their espresso machine to talk to users – after it takes your order first, of course.

**Above** The office espresso machine was ‘Houndified’, and can now hold a conversation as it brews your coffee

## HOUND: OUT NOW

Hound, the first-party app that uses Houndify on iOS and Android, has been in private beta since it was announced last year. By the time you read this magazine, the full version will be out for everyone to use. It makes use of all the excellent features if Houndify for a better voice-control experience on your device. It’s not on the Raspberry Pi, but it’s definitely worth a look!

# RASPBERRY JAM EVENT CALENDAR

Find out what community-organised, Raspberry Pi-themed events are happening near you...

## PUT YOUR EVENT ON THE MAP

Want to add your get-together? List it here:  
[raspberrypi.org/jam/add](http://raspberrypi.org/jam/add)

**1 RASPBERRY PI BIG BIRTHDAY WEEKEND**  
**When:** Weekend 5–6 March  
**Where:** University of Cambridge Computer Laboratory, Cambridge, UK  
[magpi.cc/1Sx4meX](http://magpi.cc/1Sx4meX)  
 Celebrate the Pi's fourth birthday at this weekend-long jam.

**2 PRESTON RASPBERRY JAM**  
**When:** Monday 7 March  
**Where:** Media Innovation Studio, Preston, UK  
[magpi.cc/1Pgysj4](http://magpi.cc/1Pgysj4)  
 Learn what you can do with a Raspberry Pi computer in an open, sharing, family-friendly environment.

**3 SWAB PI INTEREST GROUP**  
**When:** Wednesday 9 March  
**Where:** Roebuck Pub, Winchester, UK  
[magpi.cc/1PgyqaY](http://magpi.cc/1PgyqaY)  
 Southampton, Winchester, Andover, and Basingstoke Raspberry Pi enthusiasts have a drink and play with Pis.

**4 CORNWALL TECH JAM**  
**When:** Saturday 12 March  
**Where:** Bodmin College, Bodmin, UK  
[magpi.cc/1okaryY](http://magpi.cc/1okaryY)  
 An event for anyone who's interested in computing and technology – all ages are welcome to attend.

**5 YORKSHIRE MARS MISSION**  
**When:** Saturday 12 March  
**Where:** Swallow Hill Community College, Leeds, UK  
[magpi.cc/1okaqeg](http://magpi.cc/1okaqeg)  
 Explore the opportunities of the Raspberry Pi and help launch a Mars mission... sort of.

**6 HANDS-ON RASPBERRY PI COMPUTING**  
**When:** Wednesday 16 March  
**Where:** Wyche Innovation Centre, Malvern, UK  
[magpi.cc/1okauL6](http://magpi.cc/1okauL6)  
 A series of informal hands-on Pi workshops to encourage those who don't have access to one.

**8 RASPBERRY PI DC MEETUP**  
 Washington DC, USA

**7 RASPBERRY JAM BOGOTA 2016**  
 Bogotá, Colombia

**4 CORNWALL TECH JAM**

Bodmin, UK

**2 PRESTON RASPBERRY JAM**

Preston, UK

**5 YORKSHIRE MARS MISSION**

Leeds, UK

**1 RASPBERRY PI BIG BIRTHDAY WEEKEND**

Cambridge, UK

**6 HANDS-ON RASPBERRY PI COMPUTING**

Malvern, UK

**3 SWAB PI INTEREST GROUP**

Winchester, UK

**7 RASPBERRY JAM BOGOTA 2016****When:** Friday 18 March**Where:** Universidad Pedagogica Nacional, Bogotá, Colombia[magpi.cc/1okavyI](http://magpi.cc/1okavyI)

This year, the plan is to promote the use of the Raspberry Pi and build the Colombian Pi community.

**8 RASPBERRY PI DC MEETUP****When:** Saturday 19 March**Where:** Diference Engine, Washington DC, USA[magpi.cc/1okaAm1](http://magpi.cc/1okaAm1)

Learn how to always keep track of your Raspberry Pi 2 on the internet, with a talk about xProDDNS.

**DON'T MISS: RASPBERRY PI BIG BIRTHDAY WEEKEND****When:** Weekend 5-6 March **Where:** University of Cambridge Computer Laboratory

The Raspberry Pi is now four years old! Celebrate its birthday and find out what all the fuss is about at the same fantastic venue for last year's event. There'll be lots of vendors and demo tables, including the team from The MagPi. There's also a party on the Saturday evening, separate from the rest of the weekend's activities. For more details, check out the event page: [magpi.cc/1Sx4meX](http://magpi.cc/1Sx4meX)





# Add a blueberry to your Raspberry Pi

## Turn your Raspberry Pi into a Multi-Purpose IoT Controller Board

The Blueberry IoT Controller for the Raspberry Pi is a versatile device designed to interact with the real world by reading sensors, controlling electrical equipment and using popular communication channels.

It is supported by a range of other devices which can turn your Raspberry Pi into the nerve centre of a simple or complex monitoring and control system.



## CONTROL

**gates, garage doors, air-conditioning, irrigation systems and much more.**

Use the power and connectivity of the Pi or the on-board GSM to control your system from anywhere in the world or receive reports and alerts via email or texts (SMS).



# www.rapidonline.com

Rapid Electronics part of the **CONRAD** Group



# IQaudio

Audiophile accessories for the Raspberry Pi



## Pi-DAC+

- Raspberry Pi HAT, no soldering required
- Full-HD Audio (up to 24bit/192MHz)
- Texas Instruments PCM5122
- Variable output to 2.1v RMS
- Headphone Amplifier / 3.5mm socket
- Out-of-the-box Raspbian support
- Integrated hardware volume control
- Access to Raspberry Pi GPIO
- Connect to your own Hi-Fi's line-in/aux
- Industry standard Phono (RCA) sockets
- Supports the Pi-AMP+



## Pi-AMP+

- Pi-DAC+ accessory, no soldering required
- Full-HD Audio (up to 24bit/192MHz)
- Texas Instruments TPA3118
- Up to 2x35w of stereo amplification
- Provides power to the Raspberry Pi
- Software mute on GPIO22
- Auto-Mute when using Pi-DAC+ headphones
- Input voltage 12-19v
- Supports speakers from 4-8ohm



## Pi-DigiAMP+

- Raspberry Pi HAT, no soldering required
- Full-HD Audio (up to 24bit/192MHz)
- Texas Instruments TAS5756M
- Up to 2x35w of stereo amplification
- Out-of-the-box Raspbian support
- Integrated hardware volume control
- Provides power to the Raspberry Pi
- Software mute on GPIO22
- I/O (i2c, 3v, 5v, 0v, GPIO22/23/24/25)
- Just add speakers for a complete Hi-Fi
- Input voltage 12-19v
- Supports speakers from 4-8ohm



Twitter: @IQ\_audio  
Email: info@iqaudio.com

WWW.IQAUDIO.COM

IQaudio Limited,  
Swindon, Wiltshire.  
Company No.: 9461908



# CHECK OUT THE LATEST RASPBERRY PI CASES



ALL YOUR **RASPBERRY PI** CASE NEEDS COVERED!

**PI ZERO CASES AVAILABLE!**

**WE'VE GOT CASES FOR  
YOUR EVERY PI NEED!**

- Latest Pi Model B
- New Pi Zero
- Spi-Box
- MEDIAPI
- PiFace
- LCD Control cases



[www.sb-components.co.uk](http://www.sb-components.co.uk)

Call: **0203 514 0914**

At **SB Components** we strive to offer our customers the best prices for the best products. Our product team works tirelessly to source top quality affordable components from around the world. Raspberry Pi is a trademark of the Raspberry Pi Foundation. Raspberry Pi not included. \*Compatible with Raspberry Pi

# YOUR LETTERS

## Missing print issues

Hi, I do like that you can download all the issues of *The MagPi*, and I do keep a collection of the PDFs on my computer to refer to when needed, but I have a hard-copy collection as well.

I noticed you've never printed issues 31 to 35 of the magazine and I was wondering if I'd missed them being printed or if you had plans to print them in the future?

I'd really enjoy completing my collection with these issues! Thanks,  
**Howard E**

Hi Howard. You haven't missed any print runs of issues 31 to 35: they were released before *The MagPi* became distributed in newsagents and other shops, starting with issue 36. What we have done, though, is collect all the great content from those issues and put them into the *Official Raspberry Pi Projects Book*.

It has 200 pages full of projects, tutorials, reviews, and features – the very same found in the original issues 31 through 35 with a couple of extras to make it truly great. It's still on sale as well, and will set you back only £12.99. You can get it from the Swag Shop ([magpi.cc/1ollas3](http://magpi.cc/1ollas3)) or alternatively from Amazon ([magpi.cc/Projects-1](http://magpi.cc/Projects-1)).

**Below**  
The Raspberry Pi 3 is here and has wireless as a lot of people wanted

## Predictions

With the release of the Pi Zero only so many months ago, what do you make of these rumours of the Raspberry Pi 3 being released? I know they're very different products, but it took a while for Raspberry Pi 2 to come out after the initial release, so should we expect one so soon? I may sound like a broken record, but I do hope it comes with WiFi on it!

**Greg**

Greg, you're in luck: if the cover of the magazine and our big feature at the start hadn't tipped you off, the Raspberry Pi 3 does exist! We're not sure what rumours you saw and how they painted the Pi 3, but as the article goes into detail explaining, the Pi 3 now clocks 50% faster with a faster processor and slightly better RAM. It also comes with wireless and Bluetooth, so yours and everyone else's wishes have been granted for a new Raspberry Pi with wireless built in!

They're also available now for the same \$35 value that the other Raspberry Pi Model Bs launched at. Check out our Pi 3 feature, if you haven't already, for more information on what exactly is new with it.

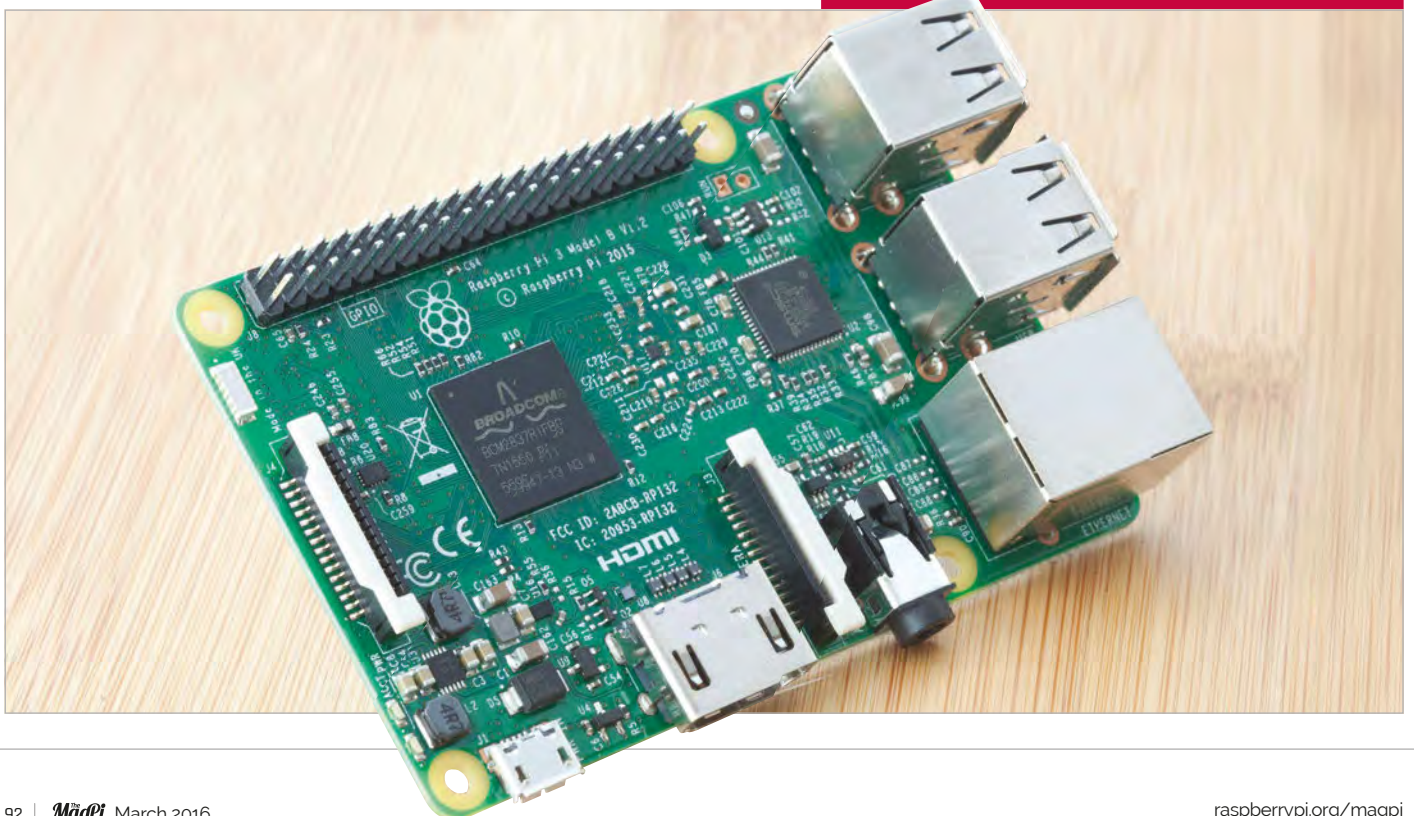



## Printed essentials

Hi MagPi, I really like your *Command Line Essentials* e-book. I know it's part of a bigger series, but is there any chance of getting a print version of this or the others? The *Command Line* would help me with some of my studies and I think the rest would be really useful in the future to me!

Thanks,  
**Mohammed Ikram**

You're in luck, Mohammed: we've just started to print out the *Essentials* books right now! This includes the first book, *Command Line Essentials*, along with our Python gaming and Sense HAT experiments books. They each cost £3.99 in print, although if you want to get them as e-books via our Android or iOS app, they'll cost you £2.99 there.

There'll be more to come in the future as well, which we'll try to print-release as well as the normal digital release. These print releases have all the same great content as the original e-books, but now with the fantastic print quality of *The MagPi* and *The Official Raspberry Pi Projects Book*.

## Contributions

Hi there! I've been reading the magazine for a while now and really enjoy it. I'm a maker or tinkerer or whatever people call themselves that mess around with electronics these days and I've used some of your ideas to improve my own projects. I was wondering if there was a way I could contribute back to the magazine, like with an article submission of a tutorial or something like that?

**Zoe B**

If you or anyone else would like to write for *The MagPi*, then we'd always like to hear from you! It's a magazine for the community, after all, so if you're in the community and think you have something good to say, then we'd love to know what it is. You can email us at our normal address ([magpi@raspberrypi.org](mailto:magpi@raspberrypi.org)), or just get in contact with us over our social media channels such as Facebook or Twitter.

We look forward to hearing from any aspiring writers!

# FROM THE FORUM: GETTING TO THE CODE

The Raspberry Pi Forum is a hotbed of conversation and problem-solving for the community – join in via [raspberrypi.org/forums](http://raspberrypi.org/forums)

**S**ome of the code examples in the magazine don't always work for copying and pasting, as they contain typographical quotation marks, which do not work in Python. Also, around dashes often there are invisible spaces, spoiling the interpretation of the code by the Python system. Would be good to leave code examples verbatim as-is, with no reformatting whatsoever, or have all of them available online via GitHub where they can be downloaded.  
**rm53**

Some of the errors when copying and pasting can sometimes just be down to your PDF reader, so if you're doing it that way, then you may need to double-check the way the code is when it's in the editor you're using.

Otherwise, most of the code is available on GitHub and we're going to start implementing our own GitHub page where any remaining code can be downloaded – it may even be up starting with this issue! Where we can, we'll put the link to these GitHub repos into tutorials.

## WRITE TO US

Have you got something you'd like to say?

Get in touch via [magpi@raspberrypi.org](mailto:magpi@raspberrypi.org) or on The MagPi section of the forum at [raspberrypi.org/forums](http://raspberrypi.org/forums)

# TAKE US ANYWHERE



**SAVE 25%**  
with a Newsstand subscription  
(limited time offer)



**DO SCIENCE WITH THE SENSE HAT**  
WITH OUR NEW **ESSENTIALS E-BOOK**  
AVAILABLE ON THE MAGPI APP!  
**ONLY £2.99 \$3.99**



**FREE: DOWNLOAD ALL 30 ORIGINAL ISSUES**

# The MagPi Magazine

Available now for smartphones & tablets



*Subscribe from*  
**£2.29 or £26.99**  
rolling subscription      full year subscription

**Download it today - it's free!**

- Get all 30 legacy issues free
- Instant downloads every month
- Fast rendering performance
- Live links & interactivity





In association with

**The Pi Hut**  
www.ThePiHut.com

**10** Raspberry Pi 3s  
**MUST BE WON!**

# HOW MANY RASPBERRY PIS DO YOU HAVE?

Tell us by 28 March for your chance to win!

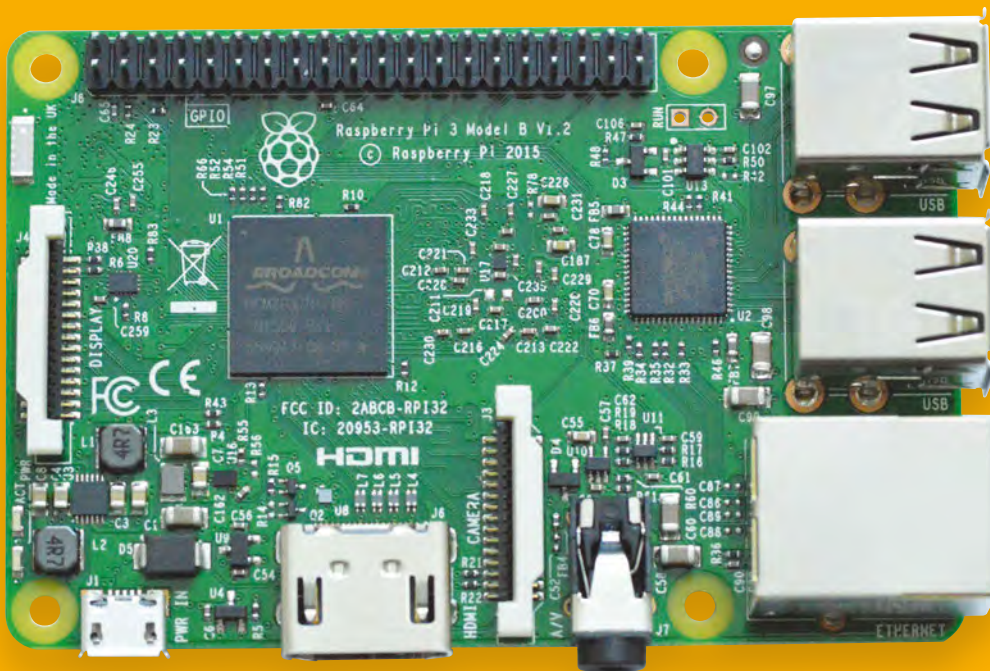

Simply email [competition@raspberrypi.org](mailto:competition@raspberrypi.org) with a 100-word (max) outline of your Pis and what you do with them...

Competition closes 28 March 2016. Prize is offered worldwide to participants aged 18 or over, except employees of the Raspberry Pi Foundation, the prize supplier, their families or friends. Winners will be notified by email after the draw date. By entering the competition, the winner consents to any publicity generated from the competition in print and online. Participants agree to receive occasional newsletters from The MagPi magazine (unless otherwise stated upon entry). We don't like spam. Participants' details will remain strictly confidential and won't be shared with third parties. Prizes are non-negotiable and no cash alternative will be offered.

## MATT RICHARDSON

Matt is Raspberry Pi's US-based product evangelist. Before that, he was co-author of *Getting Started with Raspberry Pi* and a contributing editor at *Make* magazine.



# AFFORDABLE CONNECTIVITY

**Matt Richardson** shares his excitement at Raspberry Pi 3's new features

**I**ntegrated WiFi has been at the top of Raspberry Pi feature wish-lists for a very long time. Even though our top-of-the-line model has always been equipped with an Ethernet jack and it's easy to find cheap USB WiFi dongles, there's no doubt that our community wants wireless, and they want it on-board. It's why I know you will absolutely love Raspberry Pi 3 for its built-in WiFi and Bluetooth connectivity.

Count me among all of you who wanted this for so long. Network connectivity is a must-have for the many ways I use a Raspberry Pi. I often work on my laptop and remotely log into the Pi to upload files or to control it. My projects also often use APIs for getting or posting data online or interacting with social media services. I know a lot of people who use Raspberry Pi around their homes and businesses for Internet of Things applications. For many of us, WiFi is a basic requirement for what we want to do. USB WiFi dongles have become a de rigueur accessory for Raspberry Pi.

And while WiFi is becoming increasingly ubiquitous, Ethernet connectivity remains hard to find in many places. If so many Raspberry Pi users are adding USB WiFi to their boards, it's great to be able to give them wireless connectivity out-of-the-box without even raising the price of the board.

I'm sure that Bluetooth will also be a very popular feature. It means that the Raspberry Pi will be able to talk directly to other devices, including speakers, computers, phones, watches, and other Raspberry Pis. In my office I have a Bluetooth-enabled portable photo printer that I've been eager to experiment with.

And even though the big headline about Raspberry Pi 3 is the added wireless functionality, the faster processor on the board delivers a very nice bump in performance over the Raspberry Pi 2. And if you

compare it to the very first Raspberry Pi, we're talking about major gains in speed. I've been lucky enough to spend some time with Pi 3 already. It boots up faster than ever and the desktop experience is now particularly snappy. It goes without saying that better performance means an all-around better experience for our education and hobbyist users.

## Connectivity for all

Being able to deliver the absolute best product we can while keeping the price as low as possible is a part of our mission to make computing affordable. A major aspect of that mission is helping to make connectivity affordable as well.

Take for instance the RACHEL-Pi project. It's a Raspberry Pi-based WiFi hotspot which serves offline content to devices such as tablets, mobile phones, and computers. Content modules include offline versions of Wikipedia, TED Talks, medical references, and law libraries. Along similar lines to RACHEL-Pi is the Outernet project, which also serves cached content. In the case of Outernet, the content is delivered via a satellite receiver, can be stored on a Raspberry Pi, and is supplied to WiFi-enabled devices in places where connectivity is scarce. Bundling WiFi with Raspberry Pi 3 means it will be easier and more affordable for projects like these to deliver offline content to places without internet connectivity.

Whether you're a hobbyist, a network administrator, an educator, or you're deploying an Outernet receiver in Uganda, I'm certain you'll love Raspberry Pi 3's built-in wireless connectivity and its performance gains. I see it as a win for everyone when we can scratch something off the feature wish-list without having to dig deeper into our pockets to pay for it.

# FUZE

Teaching kids to code

"The FUZE is what  
the Raspberry Pi  
was designed for"



## The FUZE T2 Case Special Edition

-  Protect your Pi from physical & static damage
-  UK keyboard\* & 4 Extra USB ports
-  FUZE I/O Board with 40 way GPIO pass-through
-  Clearly labelled input output ports
-  2 Amp power supply and on/off switch!
-  Adds analogue ports, 4 in & 1 out
-  840 pin solderless breadboard (black)



Reviewed model FUZE T2-R

**Computer act!ve**

**BUY IT AWARD**

**PC PRO Recommended**

...makes the Pi more  
accessible than ever

**micro mart**

**EDITOR'S CHOICE**

... it's certainly the **best**  
we've **ever** tested

# £99.99

FUZE T2-C-SE

\* USA & German keyboard layouts are also available. Prices include VAT but not shipping - see [fuze.co.uk](http://fuze.co.uk) for details

©2015 FUZE & the FUZE logo are trademarks of FUZE Technologies Ltd. Raspberry Pi and the Raspberry Logo are trademarks of the Raspberry Pi Foundation and are used with permission. All rights reserved.

**Compatible with  
Raspberry Pi V1 & V2**

**BONUS**  
Includes 8GB SD pre-  
configured with  
**FUZE BASIC**

FUZE Technology Ltd  
+44 (0) 1844 239 432 - [contact@fuze.co.uk](mailto:contact@fuze.co.uk)

Available from [www.fuze.co.uk](http://www.fuze.co.uk)

# CODE MUSIC

# WITH SONIC PI $\pi$

Get started today for  
**just £2.99 / \$3.99**

LIVE CODE & CREATE AMAZING SOUNDS

ON YOUR *Raspberry Pi*

*The*  
**MagPi**  
ESSENTIALS

From the makers of the  
official Raspberry Pi magazine



Available on the  
**App Store**



GET IT ON  
**Google Play**

Find it on  
*The*  
**MagPi**  
digital app

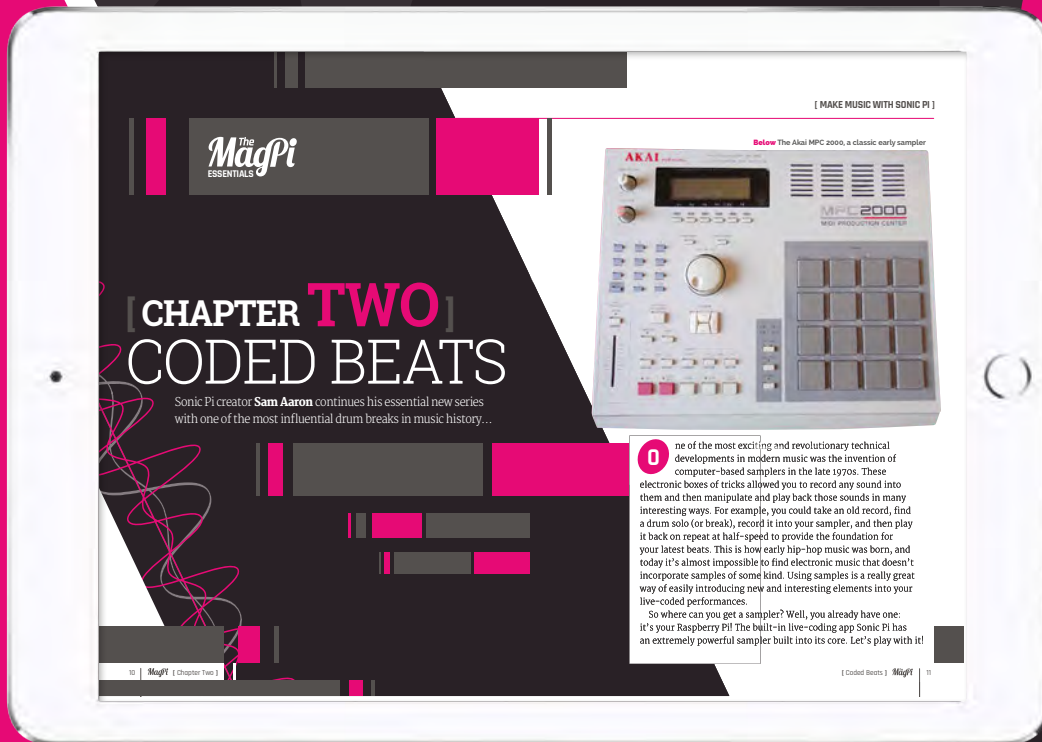

[magpi.cc/sonic-pi-book](http://magpi.cc/sonic-pi-book)